

Installation Instructions

Joint System: 650C-A07

Note: Verify that the structural gap is in conformance with submittal data before beginning installation. If this is a Fire Rated Assembly, install the fire barrier before the Architectural Joint System. Refer to the fire barrier instructions for specific system installation. See Reinforced Vapor Barrier Installs (IPC.1698) for proper installation procedures. Available on inprocorp.com under Fire + Moisture Barriers. Reference project shops before installing.

Note: for installations subject to non-conditioned applications, a thermal gap is required between the end-to-end connections of the frames and covers. When installing in warm conditions (ie- 75F / 22C or greater), the covers can abut eachother directly, however during cooler weather installs (70F / 21C or less), the recommended gap width between frames and covers is 1/8" (3mm) min. Prior to installing the next frame in sequence, apply polyurethane sealant (By Others) to the end of the frame / cover before seating the next profile.

A07 Detail

(650C-A07-200 Example)

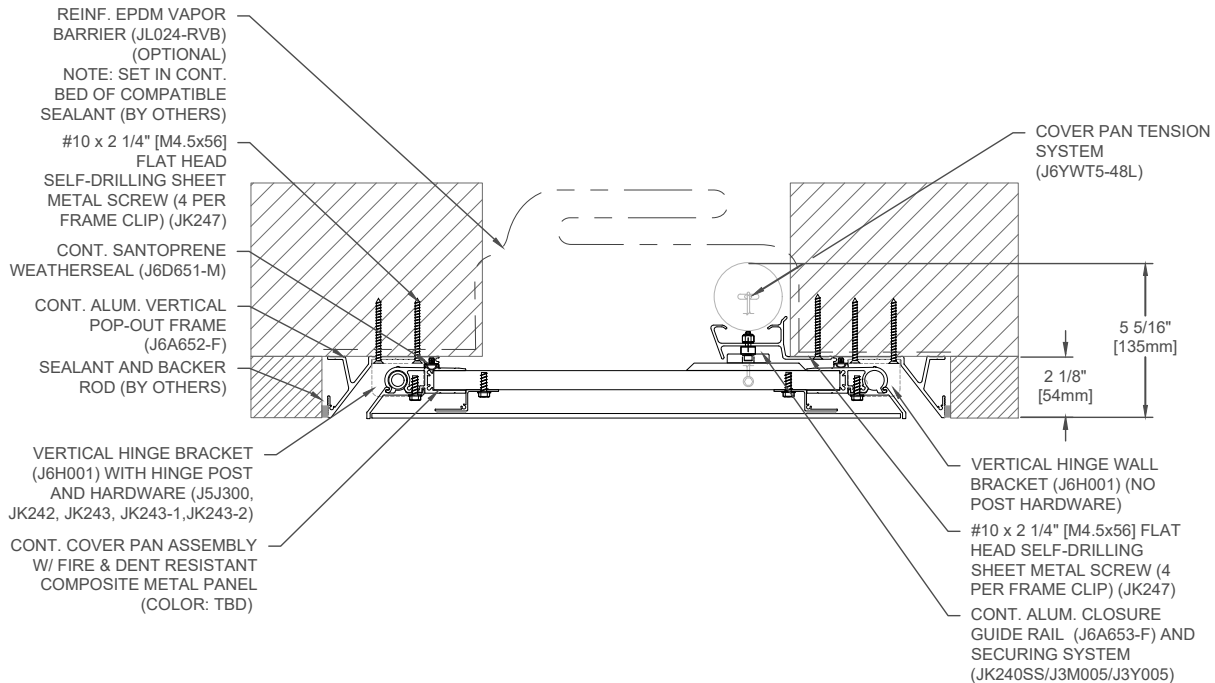

Curb Detail:

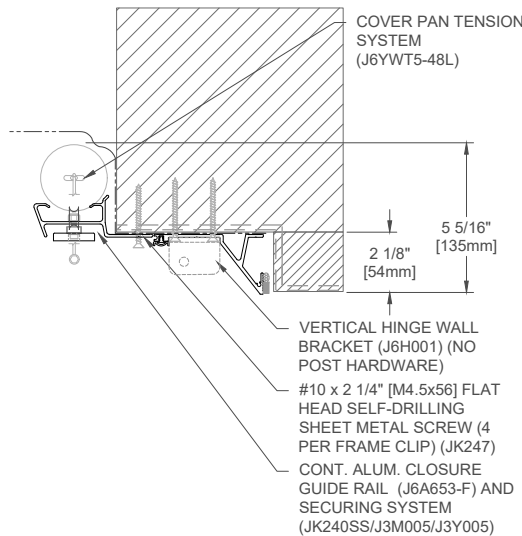

IPC.3541/REV.1

JOINTMASTER® Expansion Joint Systems

inpro.com • 800.222.5556 • 262.679.9010

World Headquarters S80 W18766 Apollo Drive, Muskego, WI 53150 USA

Installation Hotline: 866.394.6776

inpro®

Installation Instructions

Joint System: 650C-A07

Assembly Overview:

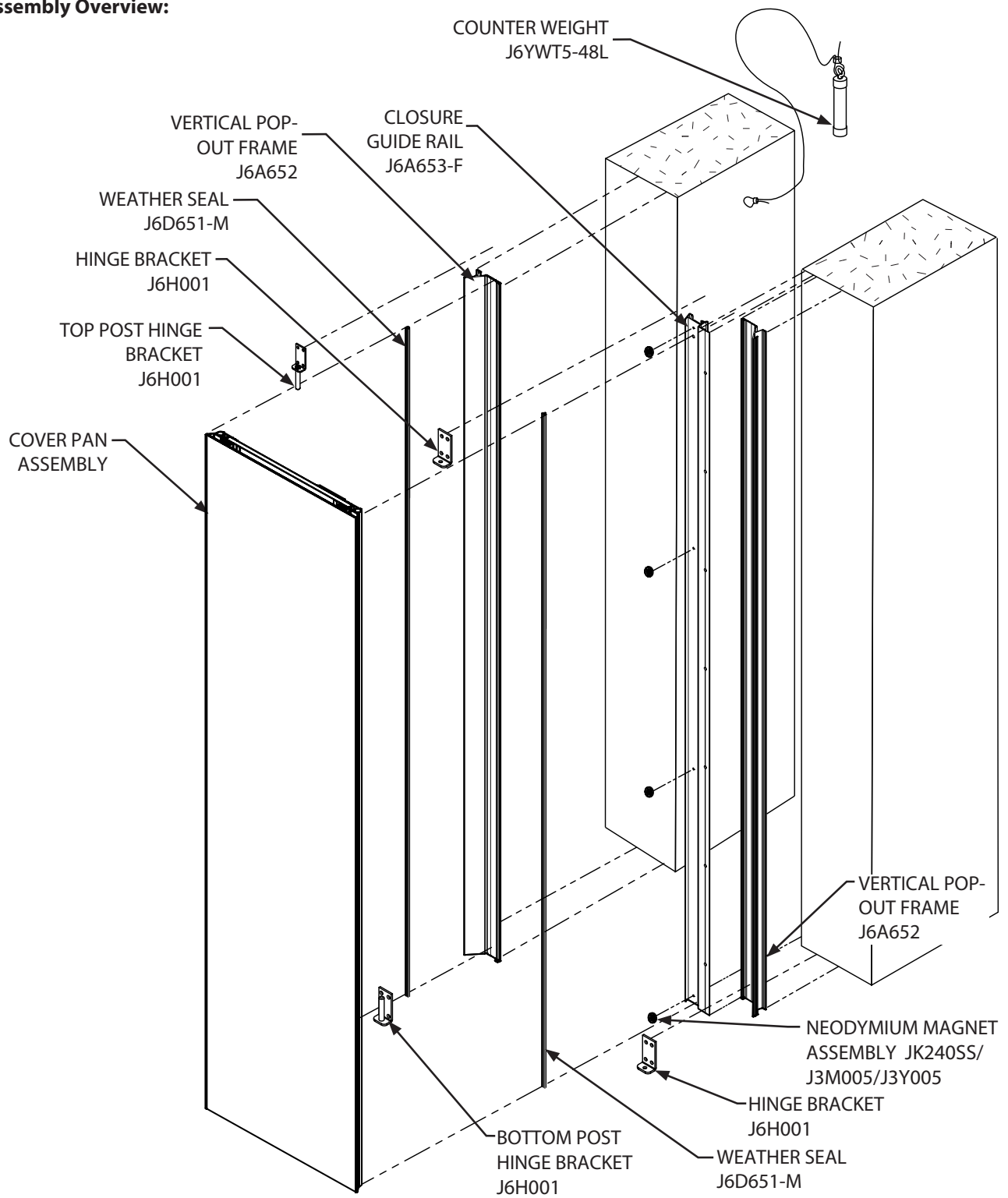

JOINTMASTER® Expansion Joint Systems

inpro.com • 800.222.5556 • 262.679.9010

World Headquarters S80 W18766 Apollo Drive, Muskego, WI 53150 USA

Installation Hotline: 866.394.6776

inpro®

Installation Instructions

Joint System: 650C-A07

Components:

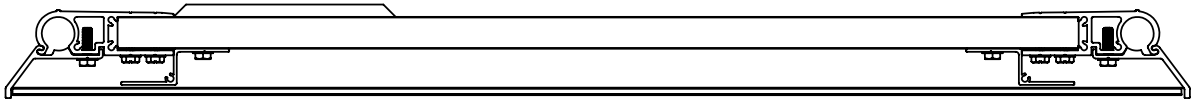

COVER PAN ASSEMBLY

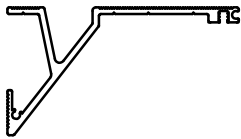

J6A652
VERTICAL POP-OUT
FRAME

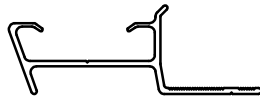

J6A653-F
CLOSURE GUIDE
RAIL



JKSS29
#10-32 x 5/8"
THREAD FORMING
SCREW



JK247
FLAT HEAD SELF-
DRILLING SHEET
METAL SCREWS



JK244
PLASTIC
GROMMET



J6D651-M
WEATHER
SEAL

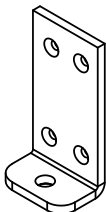

J6H001
HINGE
BRACKET

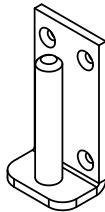

J6H001
BOTTOM
POST HINGE
BRACKET

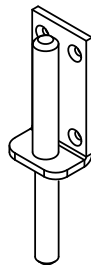

J6H001
STACKABLE
POST HINGE
BRACKET

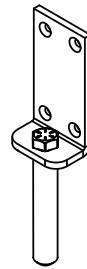

J6H001
TOP POST
HINGE
BRACKET



JK240SS/J3M005/
J3Y005
NEODYMIUM
MAGNET ASSEMBLY

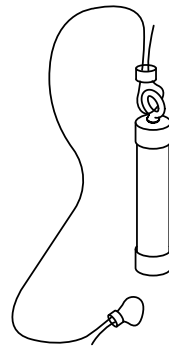

J6YWT5-48L
COUNTER WEIGHT
ASSEMBLY

JOINTMASTER® Expansion Joint Systems

inpro.com • 800.222.5556 • 262.679.9010

World Headquarters S80 W18766 Apollo Drive, Muskego, WI 53150 USA

Installation Hotline: 866.394.6776

inpro®

Installation Instructions

Joint System: 650C-A07

Figure 1 Installing the Frames

1. Install the left vertical pop-out frame 1 ½" from joint edge with flat head self-drilling sheet metal screws (7 per frame) (See Fig.1)
2. Install the closure guide rail flush to right joint edge with flat head self-drilling sheet metal screws (7 per frame) (See Fig.1)
3. Install the right vertical pop-out frame flush to closure guide rail with flat head self-drilling sheet metal screws (7 per frame) (See Fig.1)
4. Continue installation up the wall. Ensure frames are vertically plumb up wall.

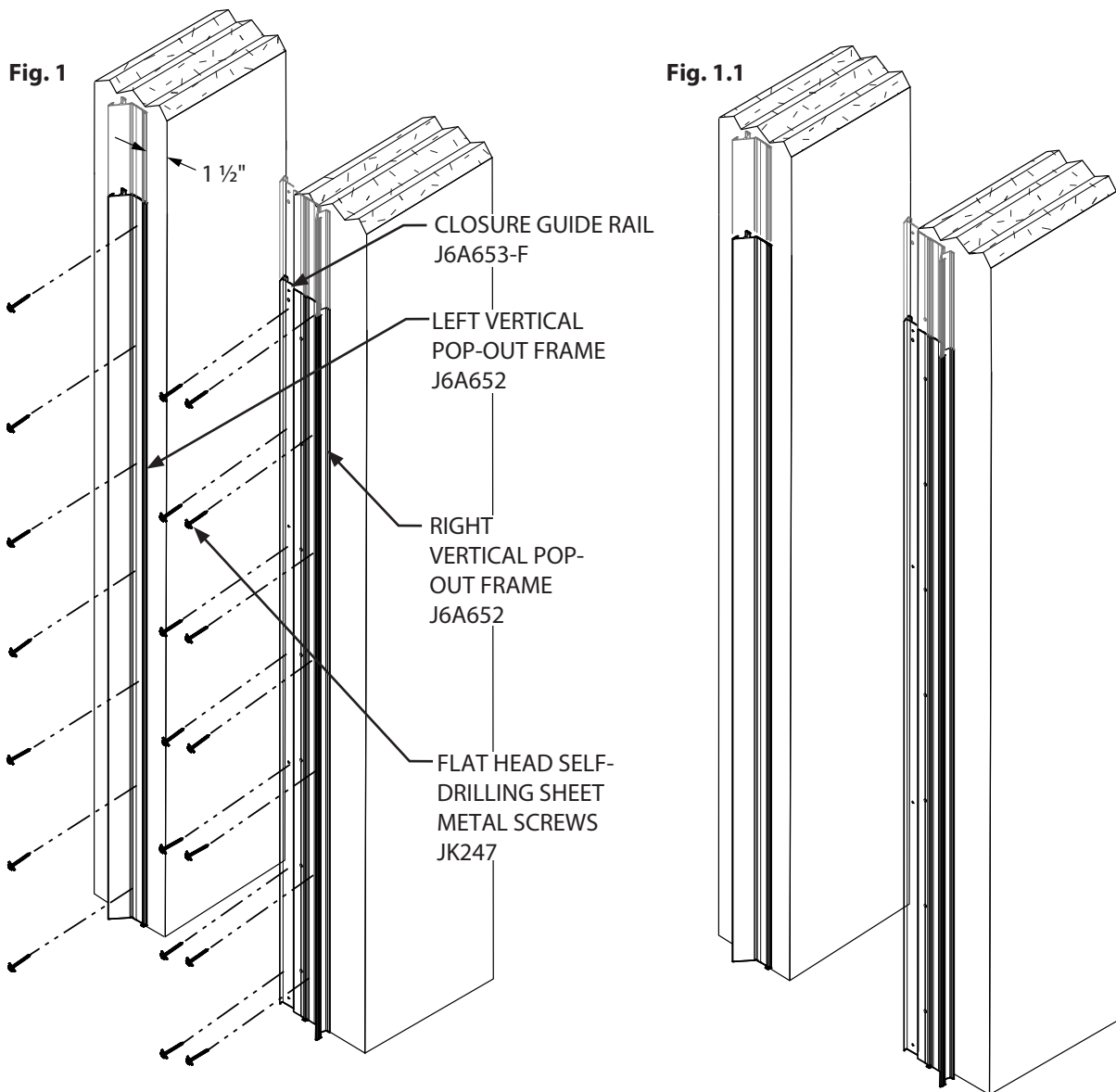

JOINTMASTER® Expansion Joint Systems

inpro.com • 800.222.5556 • 262.679.9010

World Headquarters S80 W18766 Apollo Drive, Muskego, WI 53150 USA

Installation Hotline: 866.394.6776

inpro®

Installation Instructions

Joint System: 650C-A07

Figure 2 Installing Weather Seals

5. Press weather seals into both vertical pop-out frames up full height of installation. (See Fig.2)

*NOTE: Spray soapy water into receiving channel for ease of installation.

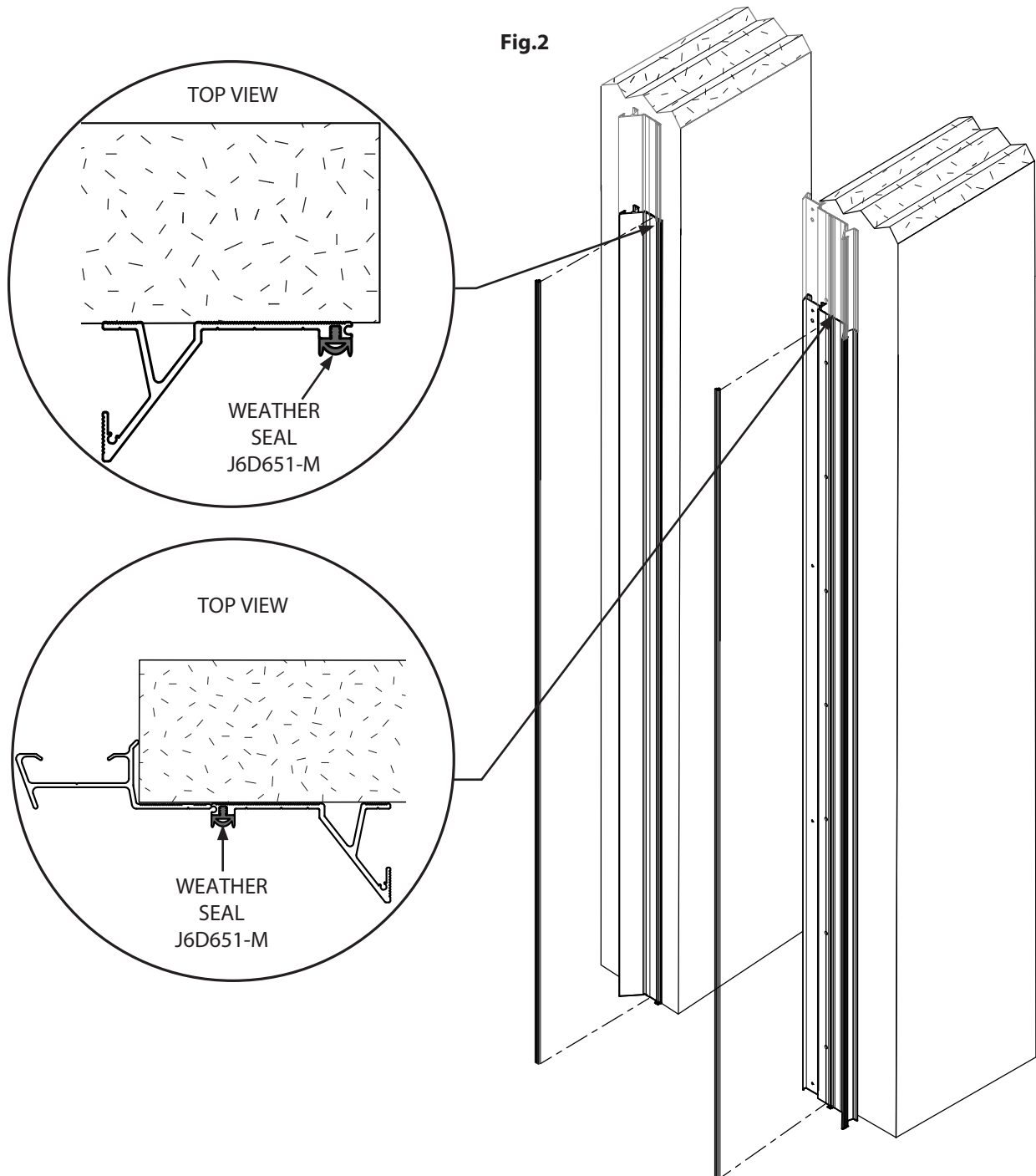

JOINTMASTER® Expansion Joint Systems

inpro.com • 800.222.5556 • 262.679.9010

World Headquarters S80 W18766 Apollo Drive, Muskego, WI 53150 USA

Installation Hotline: 866.394.6776

inpro®

Installation Instructions

Joint System: 650C-A07

Figure 3 Installing Hinge Brackets

6. Pre-assemble post hinge brackets before installing to frames. (See Fig.3)
7. Locate bottom post hinge bracket so that horizontal leg is flush to bottom hinge to align with the bottom edges of frames. Make hole locations and pre drill. Fasten brackets with flat head self-drilling sheet metal screws.(4 per bracket). (See Fig. 3.1)

Fig. 3

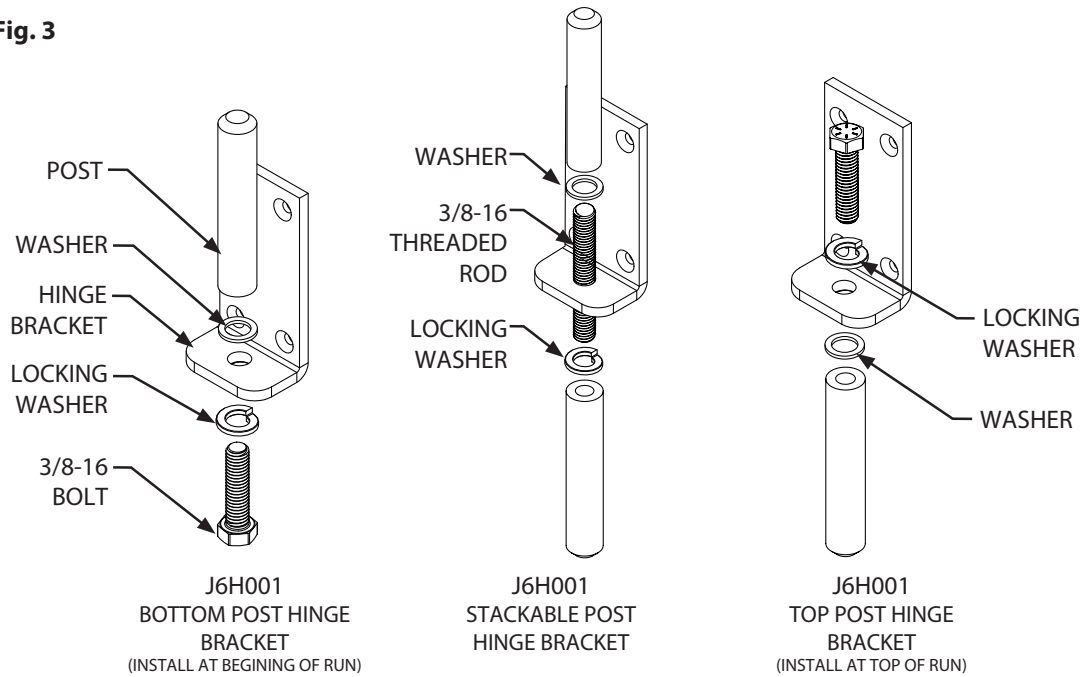
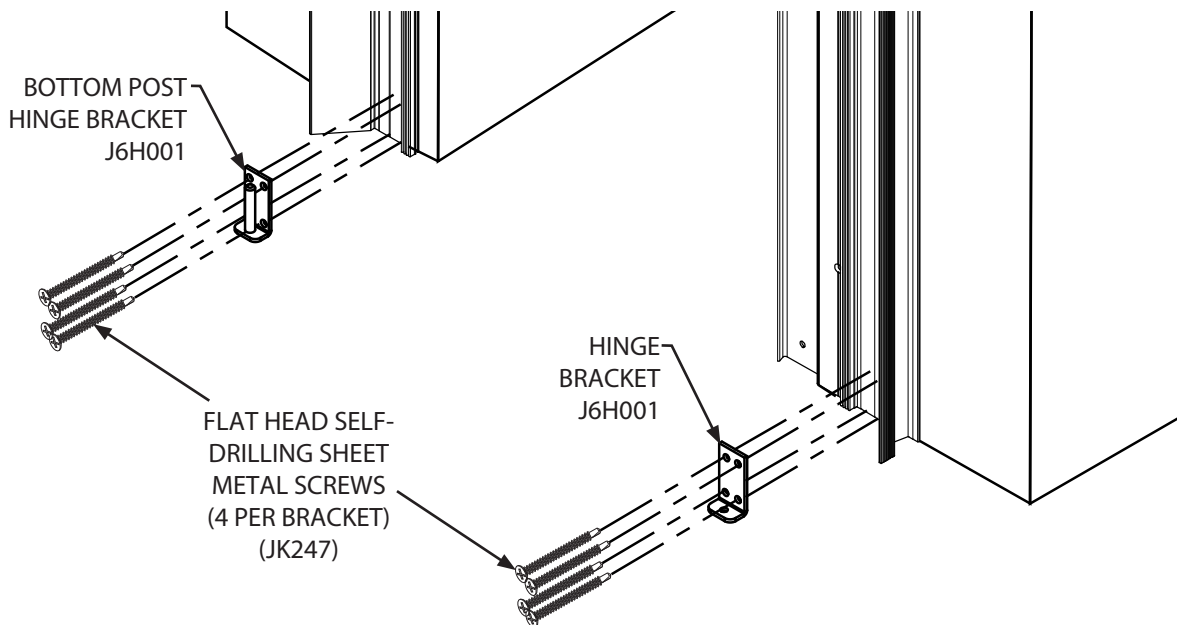

Fig. 3.1



JOINTMASTER® Expansion Joint Systems

inpro.com • 800.222.5556 • 262.679.9010

World Headquarters S80 W18766 Apollo Drive, Muskego, WI 53150 USA

Installation Hotline: 866.394.6776

inpro®

Installation Instructions

Joint System: 650C-A07

Figure 3 (Continued) Installing Hinge Brackets

8. Measure Cover Pan Assembly height to determine placement of top post hinge bracket OR stackable post hinge bracket, and hinge bracket. (Top post hinge bracket shown) Pre-drill holes at locations. (See Fig.3.2)

NOTE: If cover is last in run, cut pan assembly height to be 3" from top of substrate.

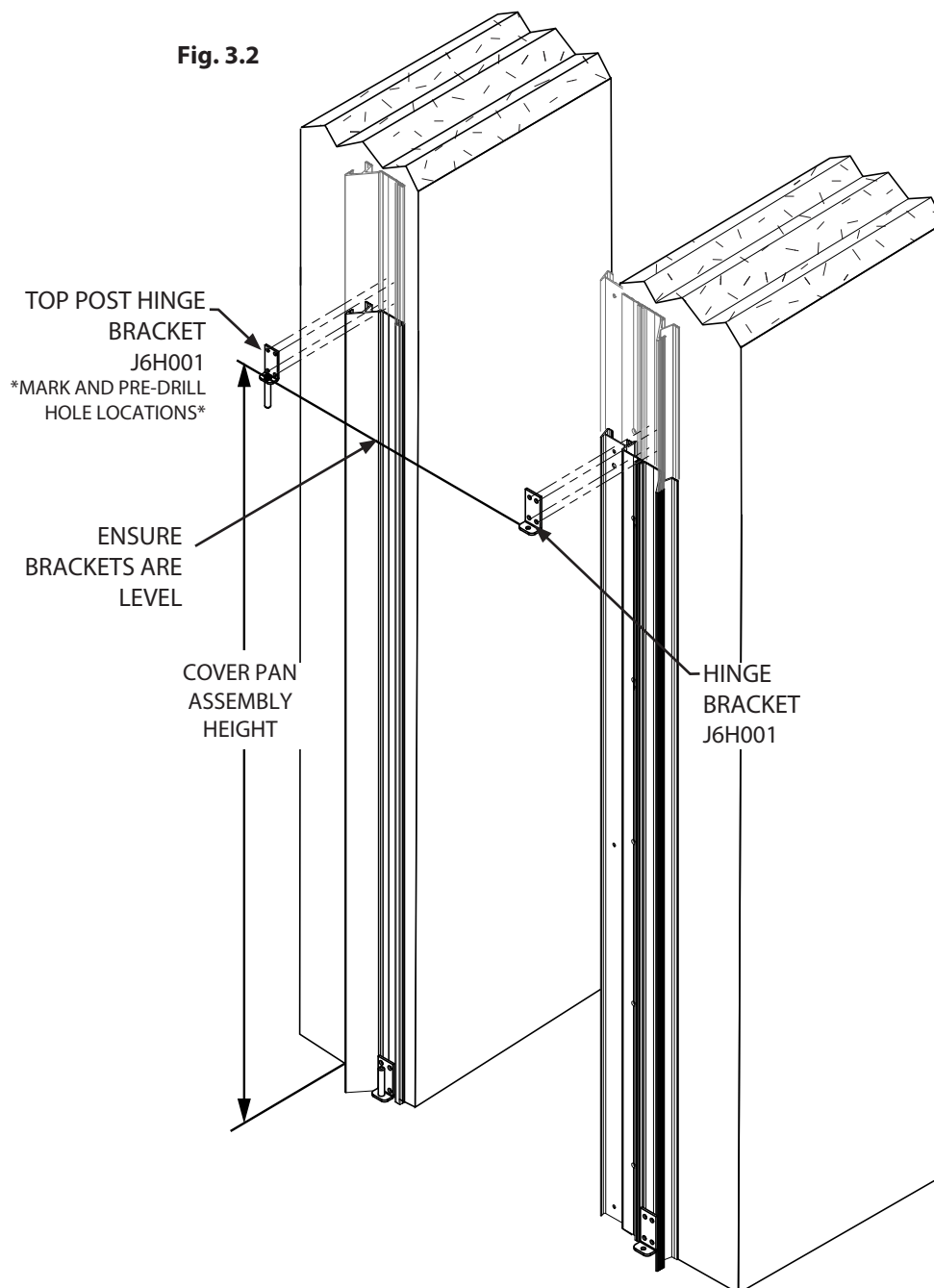

JOINTMASTER® Expansion Joint Systems

inpro.com • 800.222.5556 • 262.679.9010

World Headquarters S80 W18766 Apollo Drive, Muskego, WI 53150 USA

Installation Hotline: 866.394.6776

inpro®

Installation Instructions

Joint System: 650C-A07

Figure 4 Installing Neodymium Magnets

9. Install neodymium magnets as shown using JK240SS(x1), J3M005(x1), J3Y005(x2) (4 per frame). (See Fig.4)

10. Press fit plastic grommet into second hole from top (x1). (See Fig.4)

Fig.4

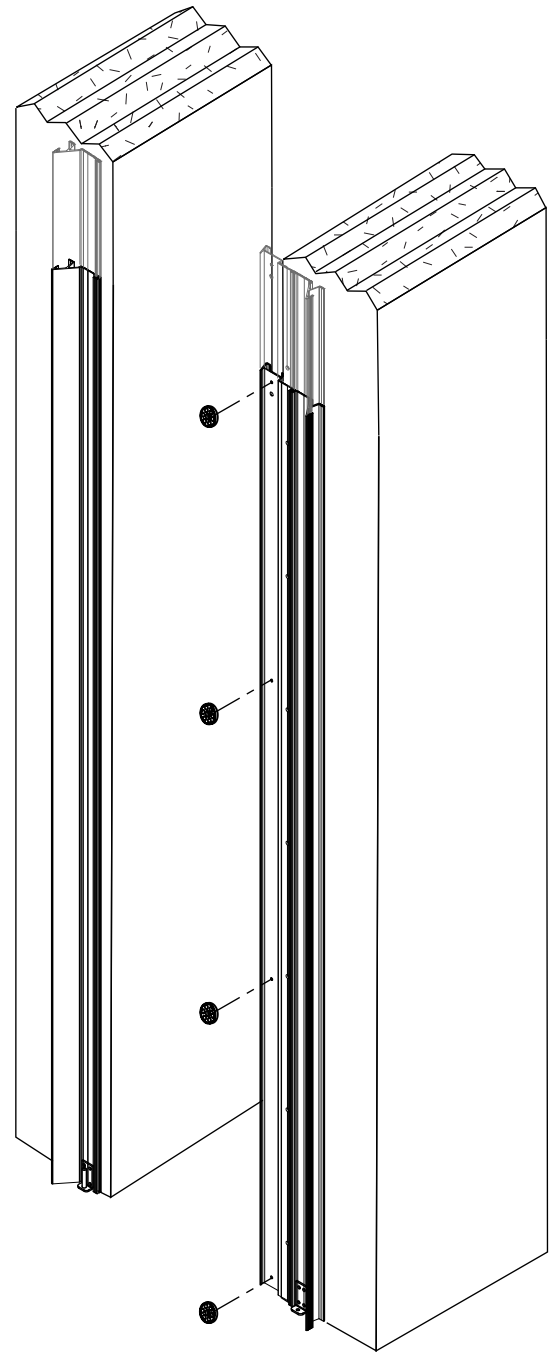
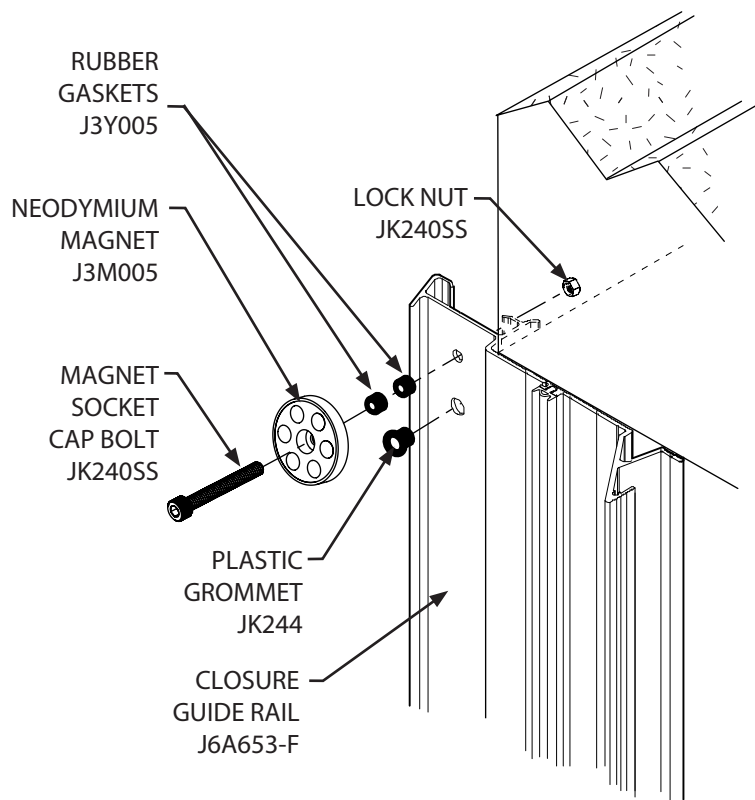

JOINTMASTER® Expansion Joint Systems

inpro.com • 800.222.5556 • 262.679.9010

World Headquarters S80 W18766 Apollo Drive, Muskego, WI 53150 USA

Installation Hotline: 866.394.6776

inpro®

Installation Instructions

Joint System: 650C-A07

Figure 5 Installing Counter Weight

11. Insert one end of cable through plastic grommet. (See Fig.5)
12. On front side of closure guide rail, slide a crimp onto cable and create a loop 1/4" - 3/8" diameter. Clamp using crimping tool to secure. (See Fig.5.1)
13. On back side of closure guide rail, slide a crimp onto cable and slide cable through eye bolt on counter weight. Loop cable around eye bolt and back into crimp. Clamp using crimping tool to secure. (See Fig.5 & Fig.5.1)

NOTE: DO NOT CRUSH MIDDLE OF CRIMP

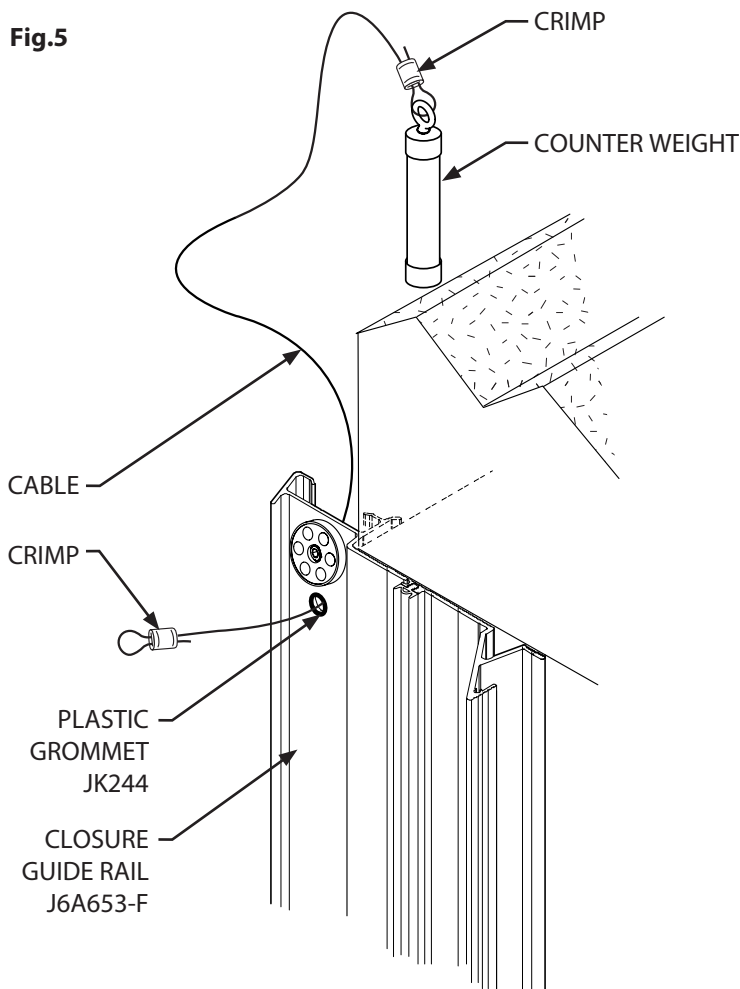
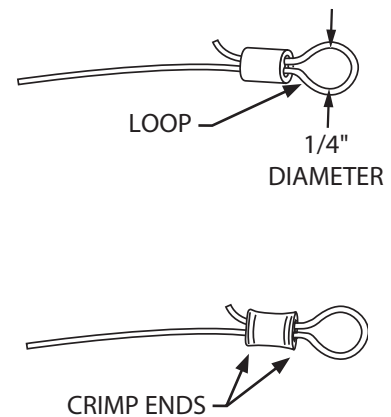

Fig.5.1



Installation Instructions

Joint System: 650C-A07

Figure 6 Installing Cover Pan Assembly

14. Drop cover pan assembly on to bottom post hinge bracket. (See Fig.6)

15. Insert top post hinge bracket OR stackable post hinge bracket into cover pan assembly. (Top post hinge bracket shown)
(See Fig.6.1)

Fig.6

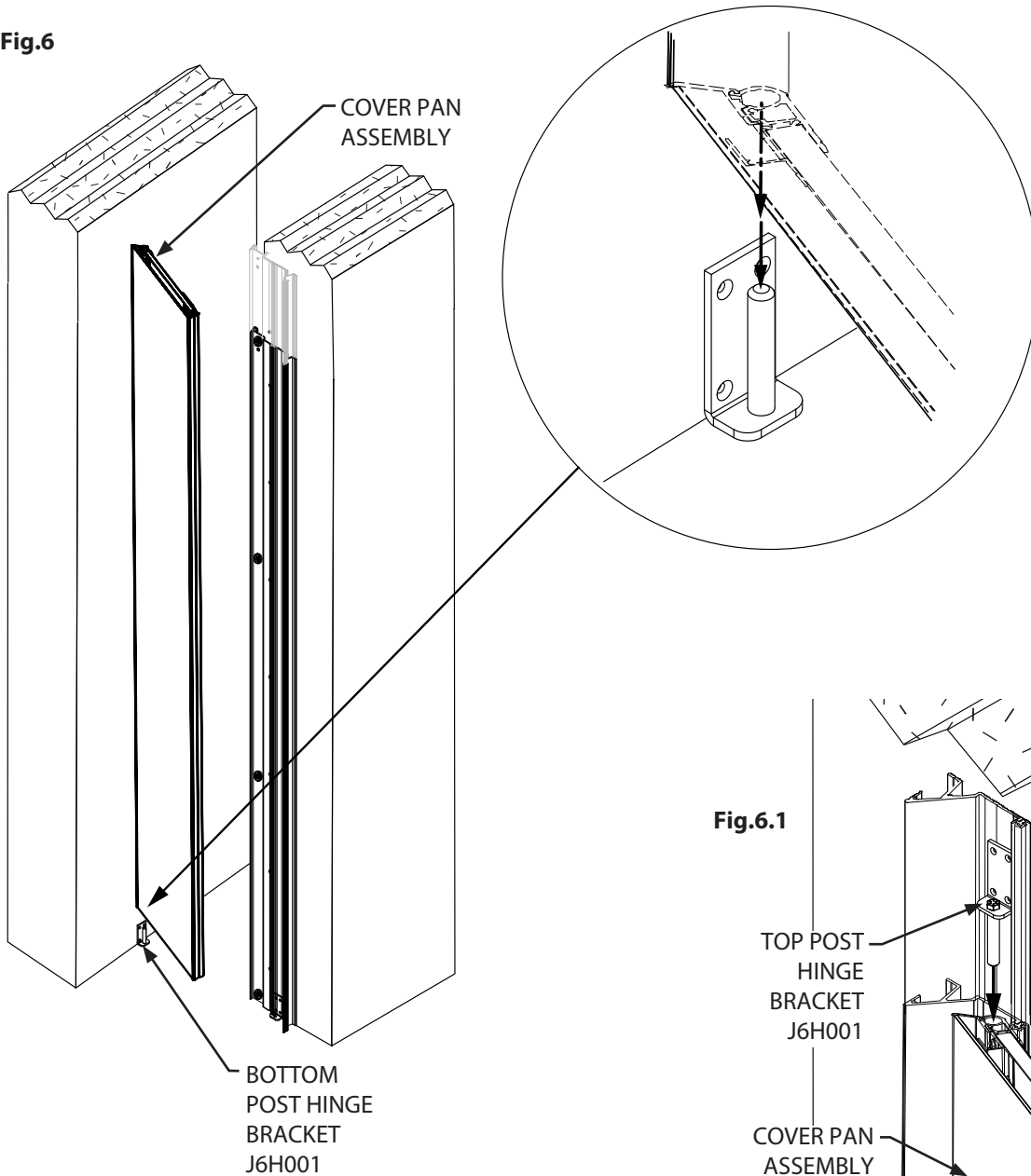
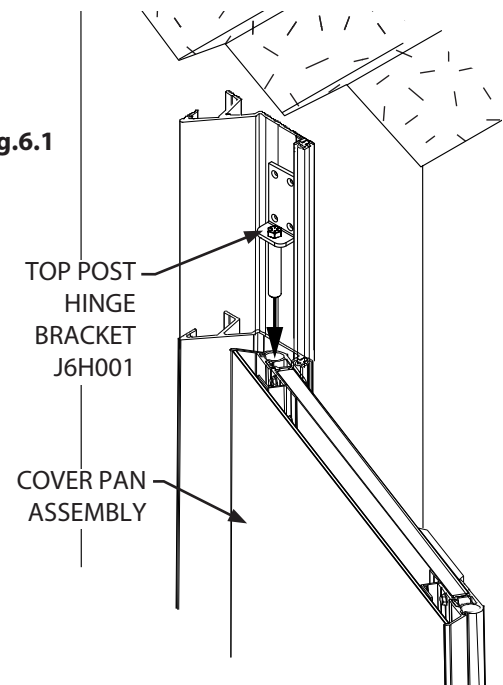

Fig.6.1



JOINTMASTER® Expansion Joint Systems

inpro.com • 800.222.5556 • 262.679.9010

World Headquarters S80 W18766 Apollo Drive, Muskego, WI 53150 USA

Installation Hotline: 866.394.6776

inpro®

Installation Instructions

Joint System: 650C-A07

Figure 6 (Continued) Installing Cover Pan Assembly

16. Install post hinge bracket and hinge bracket with flat head self drilling sheet metal screws. Ensure brackets are level across substrates. (4 per bracket) (See Fig 6.2)

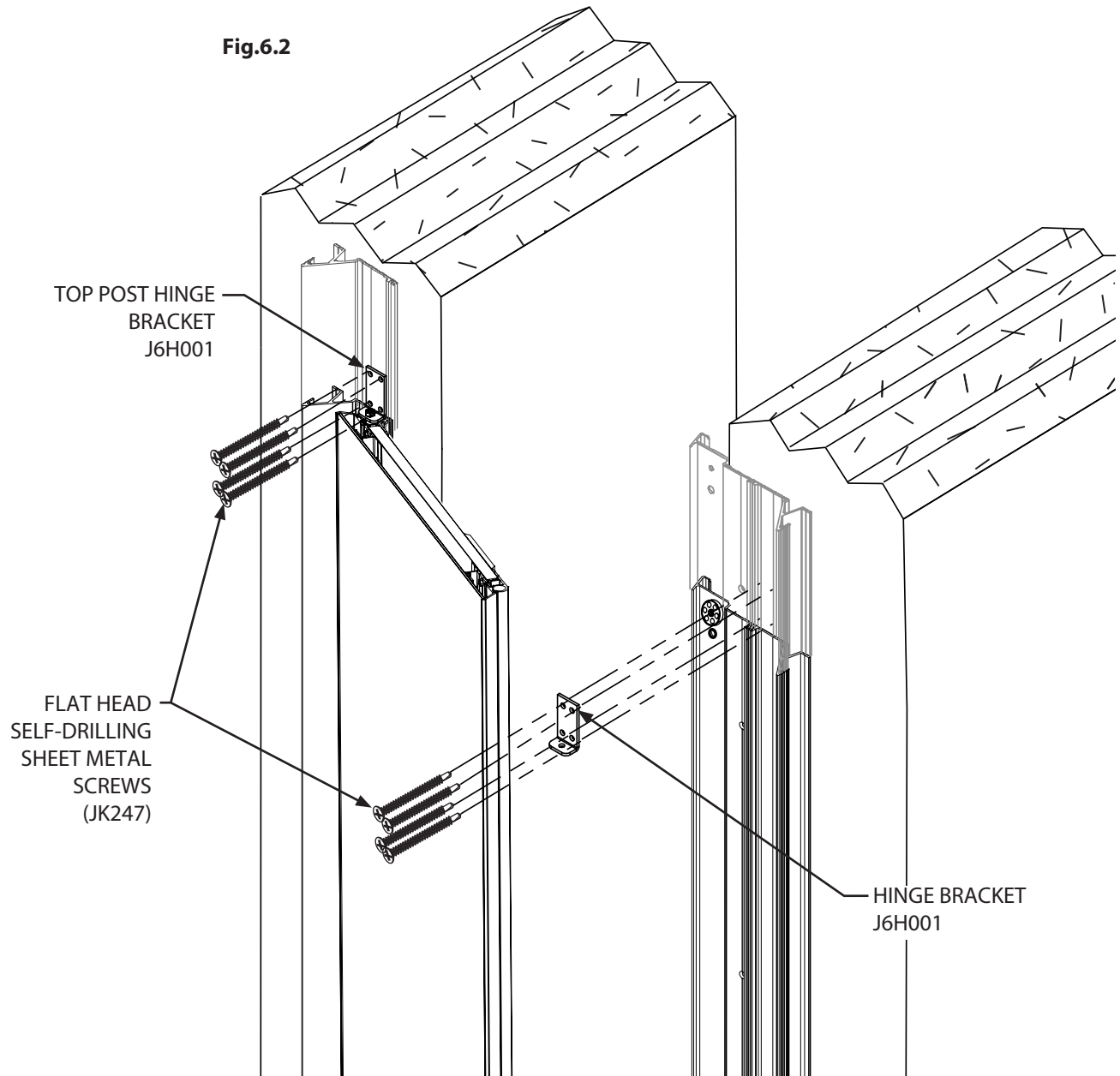

JOINTMASTER® Expansion Joint Systems

inpro.com • 800.222.5556 • 262.679.9010

World Headquarters S80 W18766 Apollo Drive, Muskego, WI 53150 USA

Installation Hotline: 866.394.6776

inpro®

Installation Instructions

Joint System: 650C-A07

Figure 7 Connecting the Counter Weight Assembly

17. Connect counter weight cable to the cover pan assembly.
18. Pre-drill and fasten #10-32x $\frac{5}{8}$ " thread forming hex head screw to underside of top horizontal rung on cover pan assembly, looping counter weight cable over screw. (See Fig.7 & Fig.7.1)
19. Continue install repeating steps 1-19.

Fig.7

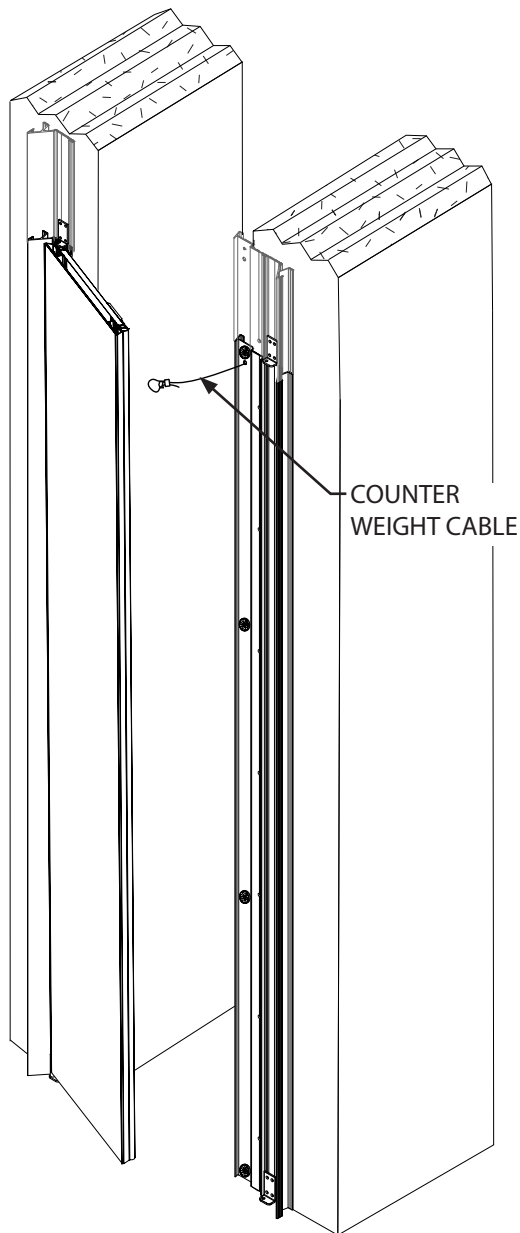
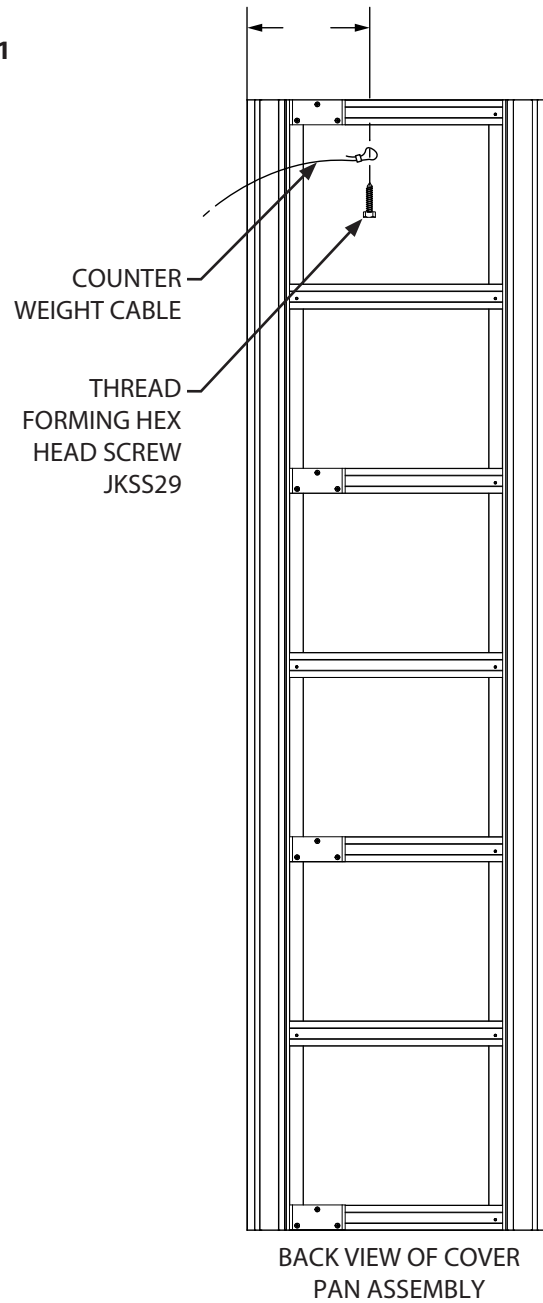

Fig.7.1



JOINTMASTER® Expansion Joint Systems

inpro.com • 800.222.5556 • 262.679.9010

World Headquarters S80 W18766 Apollo Drive, Muskego, WI 53150 USA

Installation Hotline: 866.394.6776

inpro®