

# Installation Instructions

## Joint System: 650C-A02

**Note: Verify that the structural gap is in conformance with submittal data before beginning installation. If this is a Fire Rated Assembly, install the fire barrier before the Architectural Joint System. Refer to the fire barrier instructions for specific system installation. See Reinforced Vapor Barrier Installs (IPC.1698) for proper installation procedures. Available on inprocorp.com under Fire + Moisture Barriers. Reference project shops before installing.**

**Note: for installations subject to non-conditioned applications, a thermal gap is required between the end-to-end connections of the frames and covers. When installing in warm conditions (ie- 75F / 22C or greater), the covers can abut eachother directly, however during cooler weather installs (70F / 21C or less), the recommended gap width between frames and covers is 1/8" (3mm) min. Prior to installing the next frame in sequence, apply polyurethane sealant (By Others) to the end of the frame / cover before seating the next profile.**

### A02 Detail

(650C-A02-200 Example)

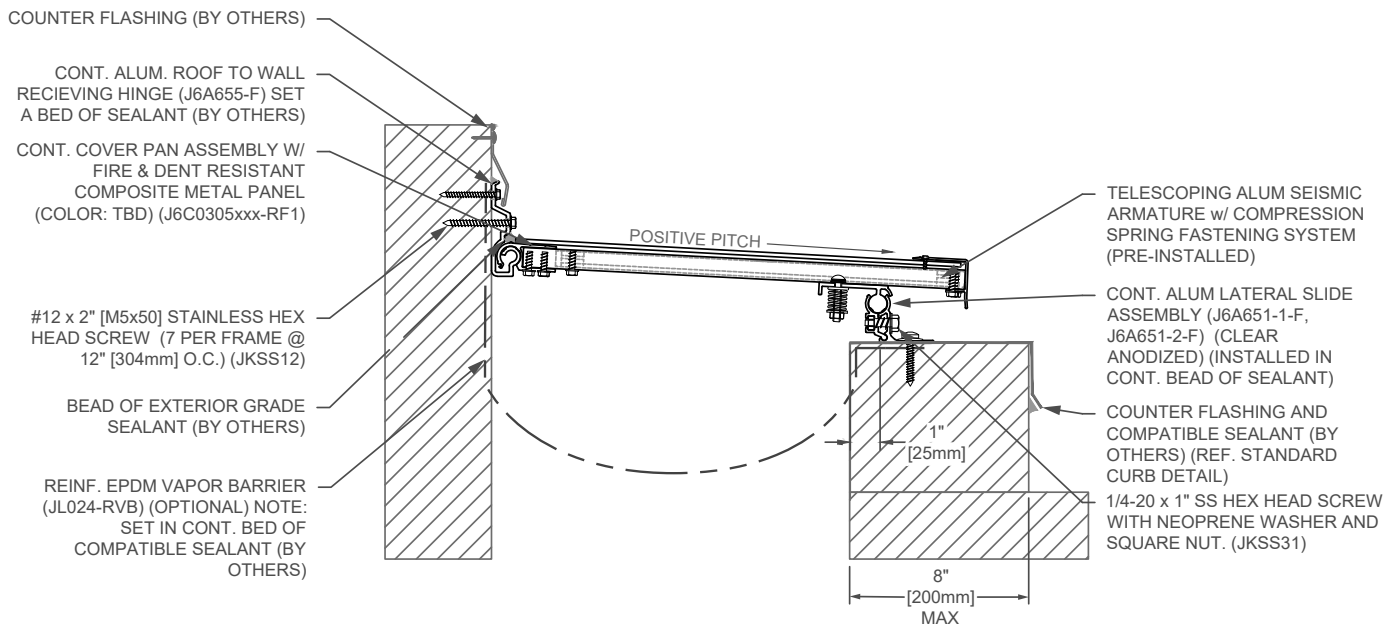

### Curb Detail:

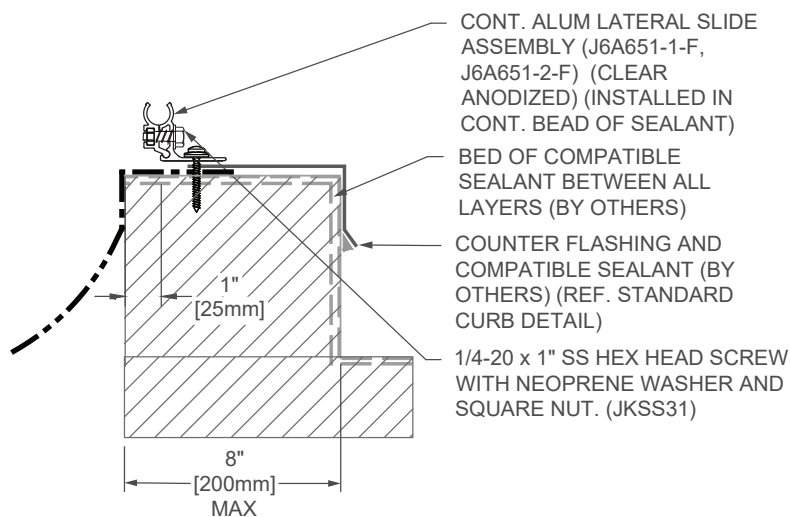

IPC .3540/REV.1

JOINTMASTER® Expansion Joint Systems

inpro.com • 800.222.5556 • 262.679.9010

World Headquarters S80 W18766 Apollo Drive, Muskego, WI 53150 USA

Installation Hotline: 866.394.6776

**inpro**®

# Installation Instructions

Joint System: 650C-A02

## Components:

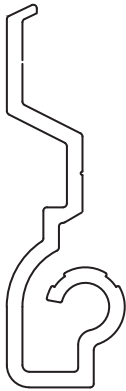
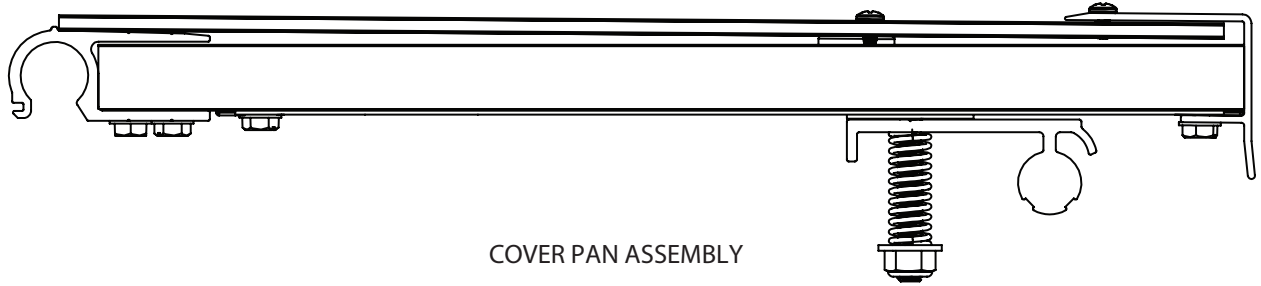

J6A655-F  
ROOF TO WALL  
RECEIVING HINGE

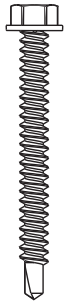

JKSS12  
#12x2" STAINLESS  
HEX HEAD SCREW

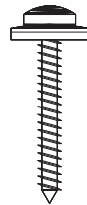

JKSS28  
#12x1 1/2" STAINLESS  
PAN HEAD SCREW

## TWO PIECE LATERAL SLIDE ASSEMBLY

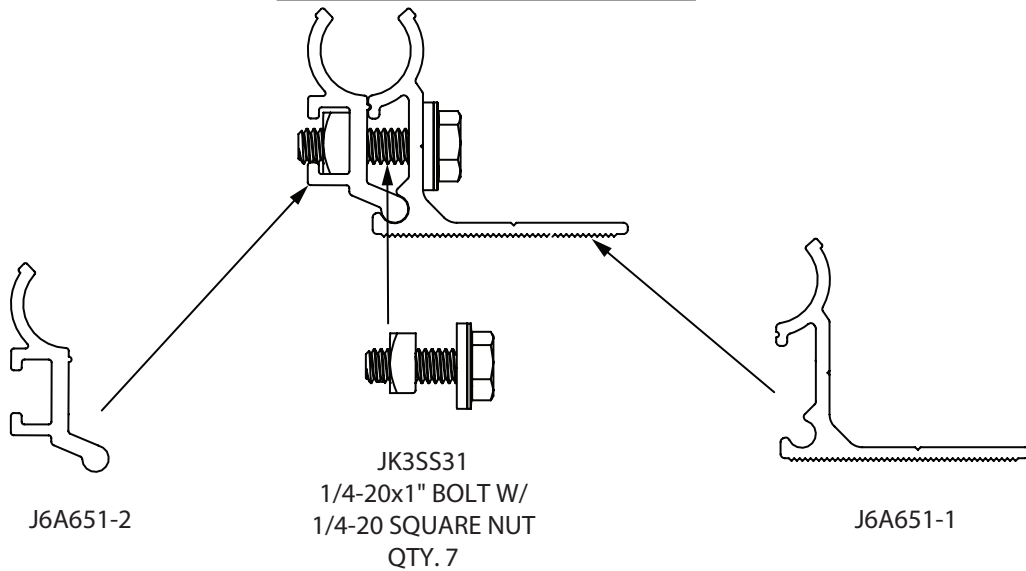

JOINTMASTER® Expansion Joint Systems

[inpro.com](http://inpro.com) • 800.222.5556 • 262.679.9010

World Headquarters S80 W18766 Apollo Drive, Muskego, WI 53150 USA

Installation Hotline: 866.394.6776

**inpro**®

# Installation Instructions

Joint System: 650C-A02

**Assembly Overview:**

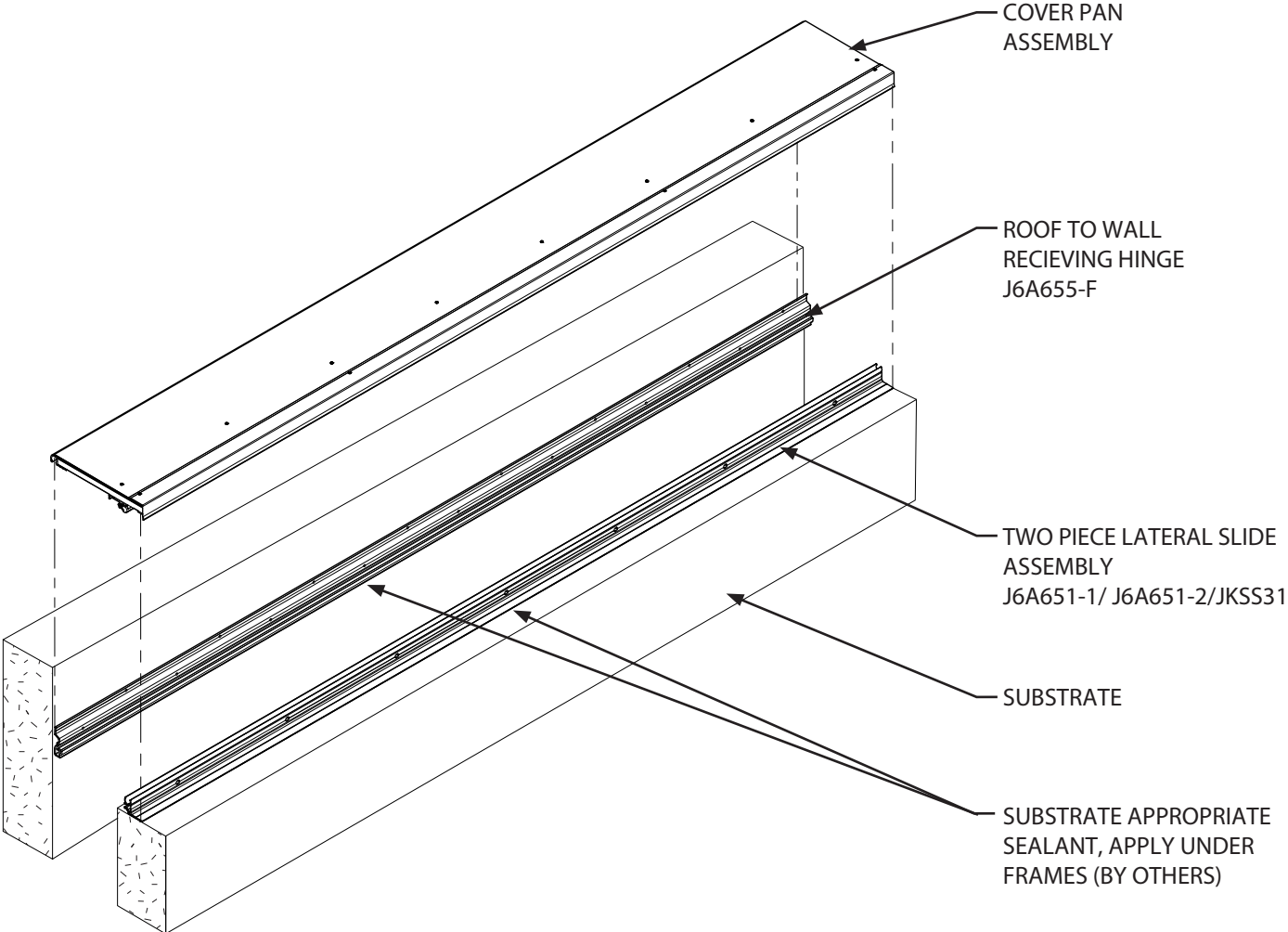

# Installation Instructions

Joint System: 650C-A02

## Figure 1 Installing Roof to Wall Receiving Hinge

1. Position the Roof to Wall Receiving Hinge against wall substrate located  $5 \frac{7}{16}$ " above adjacent curb. (See Fig.2)
2. Ensure the receiving hinge is level. Mark predrilled hole locations as shown in figure 2.1.
3. Remove hinge from wall, and drill marked holes on the curb using a  $\frac{1}{8}$ " (3mm) drill bit to a  $1 \frac{1}{2}$ " (25mm) depth.
4. Install the roof to wall receiving hinge  $5 \frac{7}{16}$ " above curb. Install to wall substrate with stainless hex head screws through the predrilled holes. (7 per frame) Two on each end and three on center. (See Fig.2.1)

Fig. 2

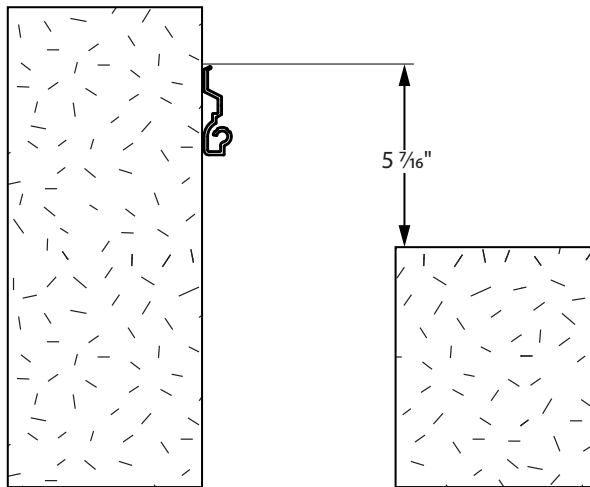
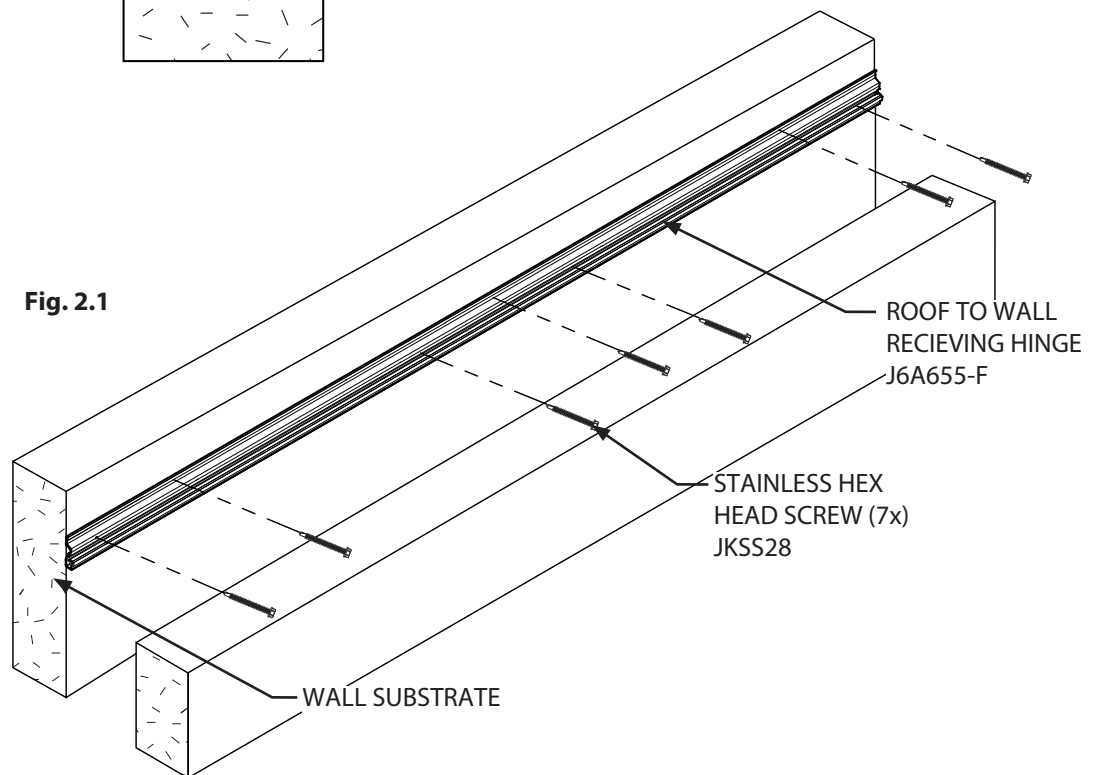

Fig. 2.1



JOINTMASTER® Expansion Joint Systems

[inpro.com](http://inpro.com) • 800.222.5556 • 262.679.9010

World Headquarters S80 W18766 Apollo Drive, Muskego, WI 53150 USA

Installation Hotline: 866.394.6776

**inpro**®

# Installation Instructions

Joint System: 650C-A02

## Figure 2 Installing the Two Piece Lateral Slide Assembly

- Slide J6A651-2 into J6A651-1. (See Fig.2)
- Slide ¼-20 square nuts into extruded slot on J6A651-2. (See Fig.2.1)
- Loosely thread the hex head screws with gasket washer into square nuts across the two piece lateral slide assembly. (See Fig.2.1)

Fig. 2

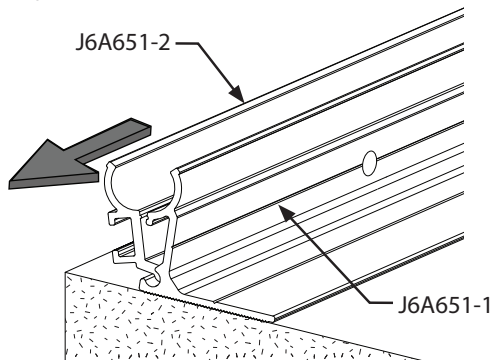
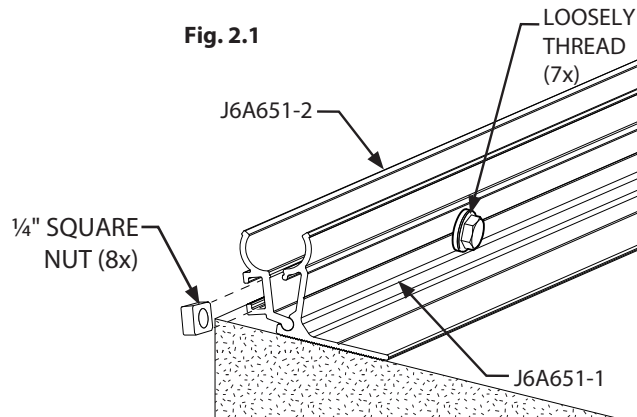

Fig. 2.1



- Position the two piece lateral slide assembly on curb located 1 ½" from joint edge. (See Fig.2.2)
- Mark predrilled hole locations as shown in figure 2.3.
- Remove frame from curb, and predrill marked holes on the curb using a 1/8" (3mm) drill bit to a 1 ½" (25mm) depth.
- Install the two piece lateral slide assembly to roof substrate with stainless pan head screws through the predrilled holes. (7 per frame) (See Fig.2.3)
  - Offset back edge of two piece lateral slide assembly 2 ⅝" from joint edge or 1" from front.

Fig. 2.2

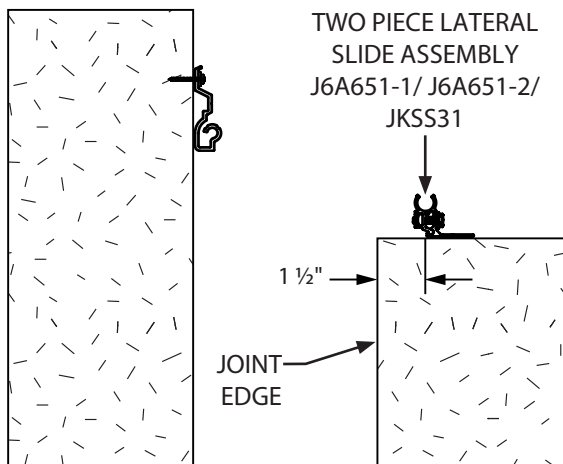
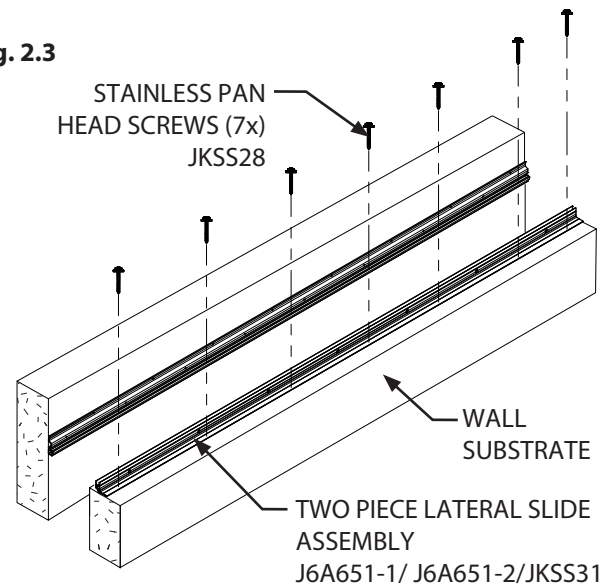

Fig. 2.3



JOINTMASTER® Expansion Joint Systems

inpro.com • 800.222.5556 • 262.679.9010

World Headquarters S80 W18766 Apollo Drive, Muskego, WI 53150 USA

Installation Hotline: 866.394.6776

**inpro**®

# Installation Instructions

Joint System: 650C-A02

## Figure 3 Installing Cover Pan Assembly

12. Apply white lithium grease to cylindrical part of the roof to wall receiving hinge (J6A650-F).
13. Slide cover pan assembly onto roof to wall receiving hinge. (See Fig. 3)

NOTE: At the end of a run, pre-assemble roof to wall receiving hinge into cover pan before installing.

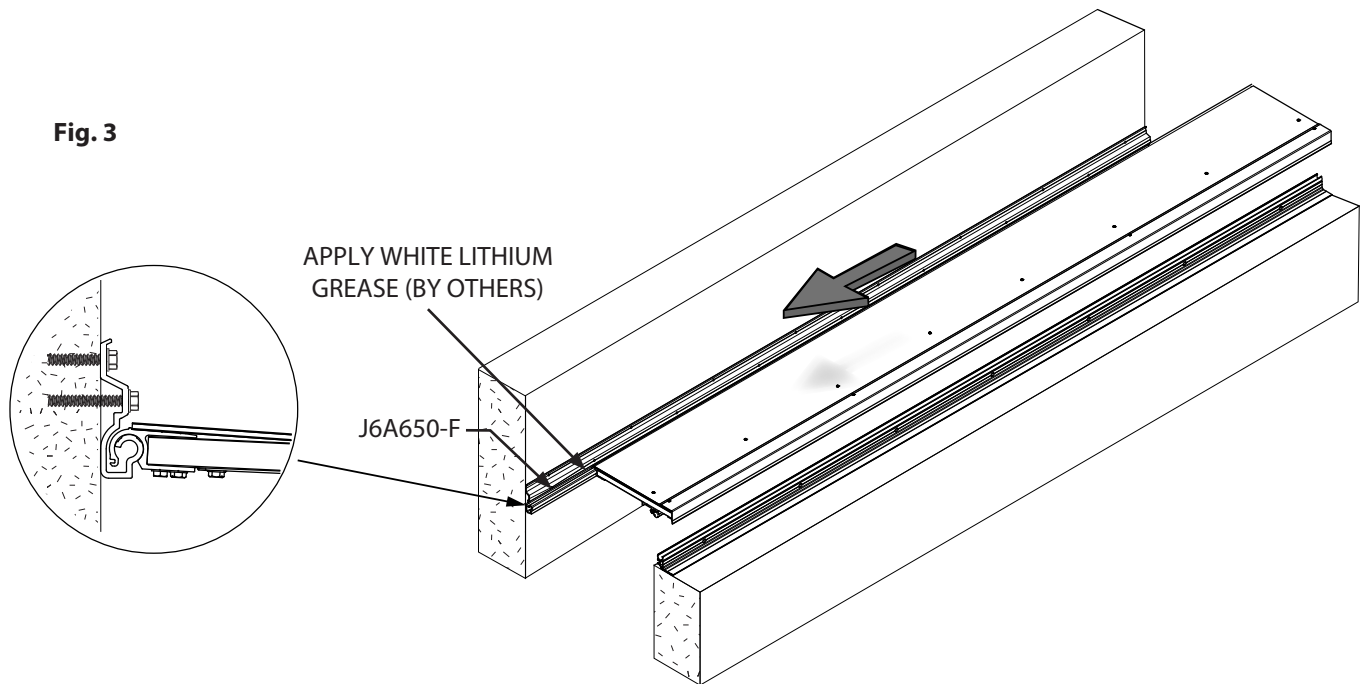

## Figure 4 Installing Cover Pan Assembly

14. Rotate cover pan assembly, seating the lateral slide frame, into the two piece lateral slide assembly. (See Fig.4 & Fig.4.1)

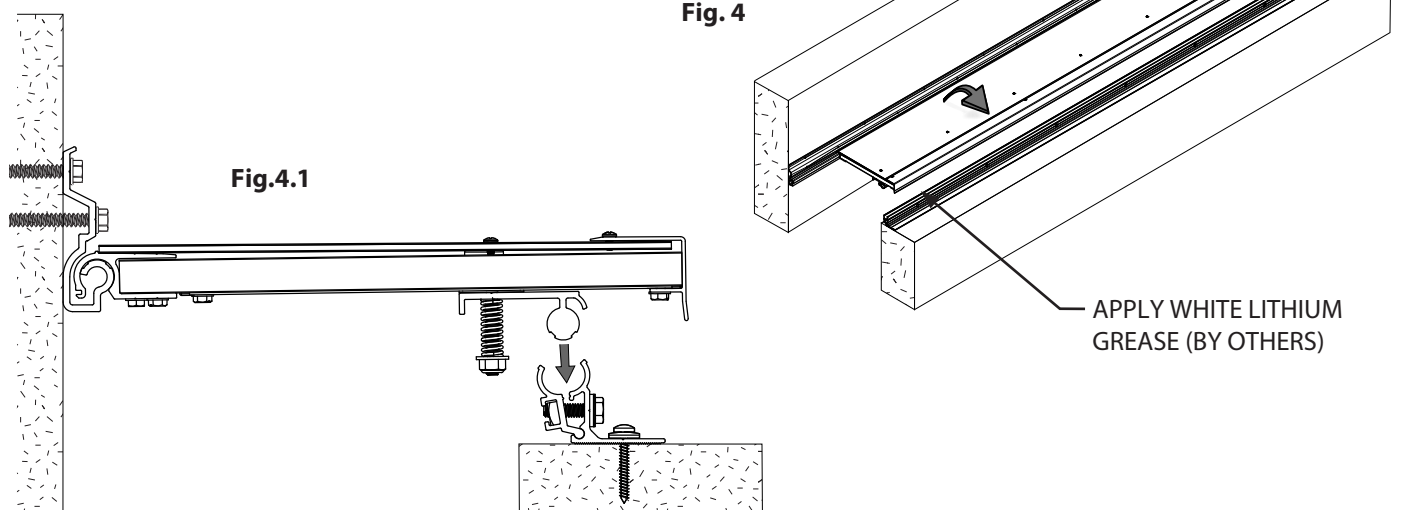

JOINTMASTER® Expansion Joint Systems

[inpro.com](http://inpro.com) • 800.222.5556 • 262.679.9010

World Headquarters S80 W18766 Apollo Drive, Muskego, WI 53150 USA

Installation Hotline: 866.394.6776

**inpro**®

# Installation Instructions

Joint System: 650C-A02

## Figure 5 Installing Cover Pan Assembly

15. Make sure the cover pan assembly rests in the two piece lateral slide assembly. (See Fig 5 and 5.1)

16. Using 7/16" socket, tighten JK31SS. (See Fig.5.2)

Fig. 5

APPLY EXTERIOR SEALANT  
ALONG LENGTH LENGTH  
(BY OTHERS)

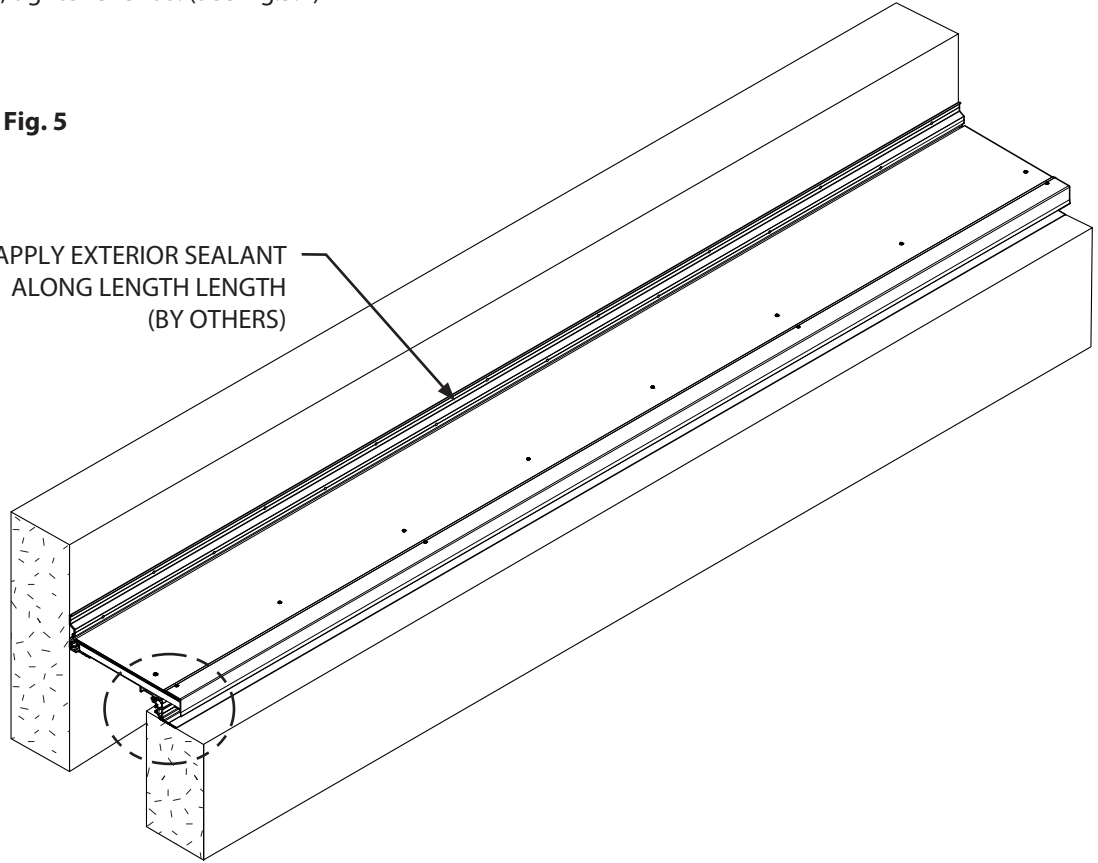

Fig. 5.1

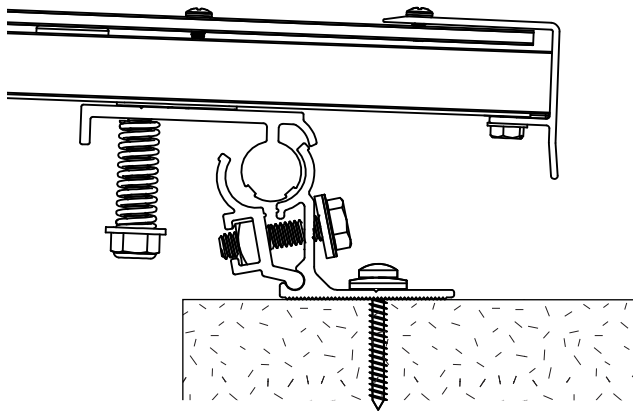
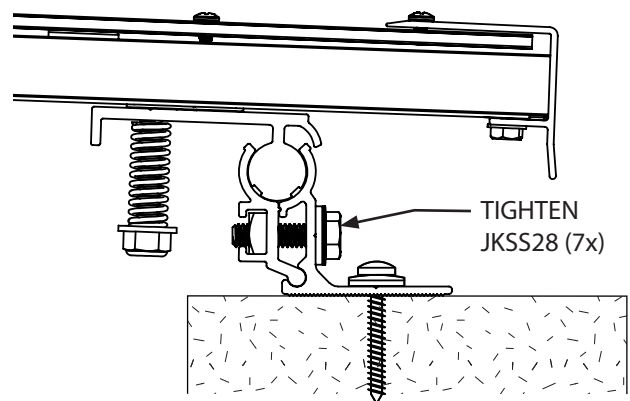

Fig. 5.2



JOINTMASTER® Expansion Joint Systems

inpro.com • 800.222.5556 • 262.679.9010

World Headquarters S80 W18766 Apollo Drive, Muskego, WI 53150 USA

Installation Hotline: 866.394.6776

**inpro**®

# Installation Instructions

## Joint System: 650C-A02

### Figure 6 Installing Splice Plate

17. Clean area using isopropol alcohol or denatured alcohol.
18. Center splice plate where cover pan assemblies meet.
19. Apply system seam sealant to top of cover pan assemblies as shown. (See Fig.6)
20. Secure splice plate with two sheet metal screws 1" from edge of splice as shown below. (See Fig.6)

**FIG.6**

**A02 to A02**

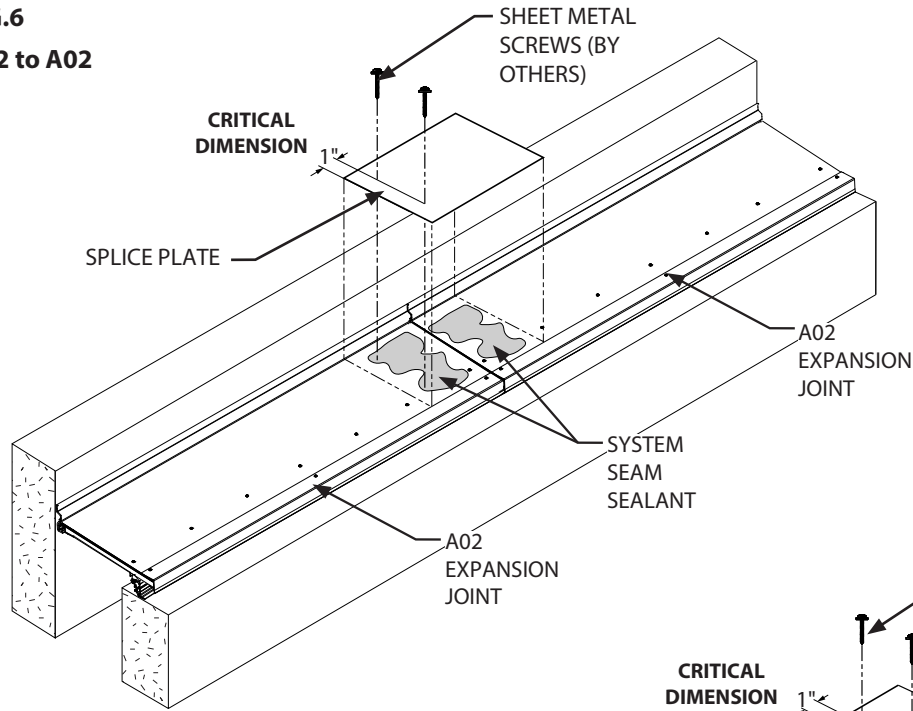

**Fig.6.1**  
**A01 to A02**

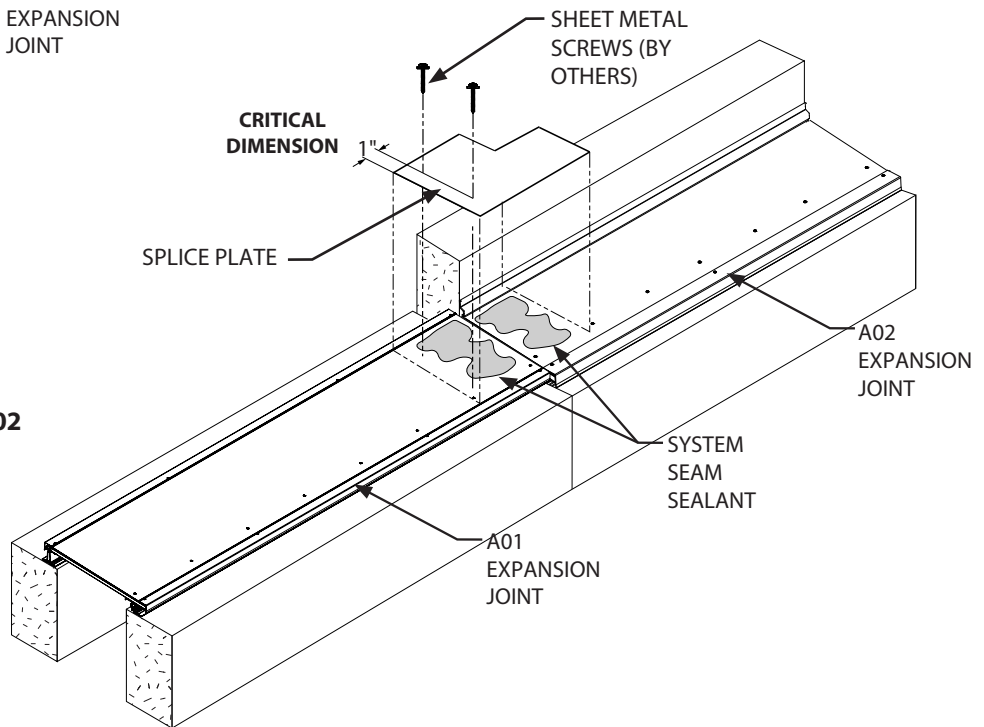

JOINTMASTER® Expansion Joint Systems

[inpro.com](http://inpro.com) • 800.222.5556 • 262.679.9010

World Headquarters S80 W18766 Apollo Drive, Muskego, WI 53150 USA

Installation Hotline: 866.394.6776

**inpro**®