

Installation Instructions

Joint System: 650C-A01

Note: Verify that the structural gap is in conformance with submittal data before beginning installation. If this is a Fire Rated Assembly, install the fire barrier before the Architectural Joint System. Refer to the fire barrier instructions for specific system installation. See Reinforced Vapor Barrier Installs (IPC.1698) for proper installation procedures. Available on inprocorp.com under Fire + Moisture Barriers. Reference project shops before installing.

Note: for installations subject to non-conditioned applications, a thermal gap is required between the end-to-end connections of the frames and covers. When installing in warm conditions (ie- 75F / 22C or greater), the covers can abut eachother directly, however during cooler weather installs (70F / 21C or less), the recommended gap width between frames and covers is 1/8" (3mm) min. Prior to installing the next frame in sequence, apply polyurethane sealant (By Others) to the end of the frame / cover before seating the next profile.

A01 Detail

(650C-A01-200 Example)

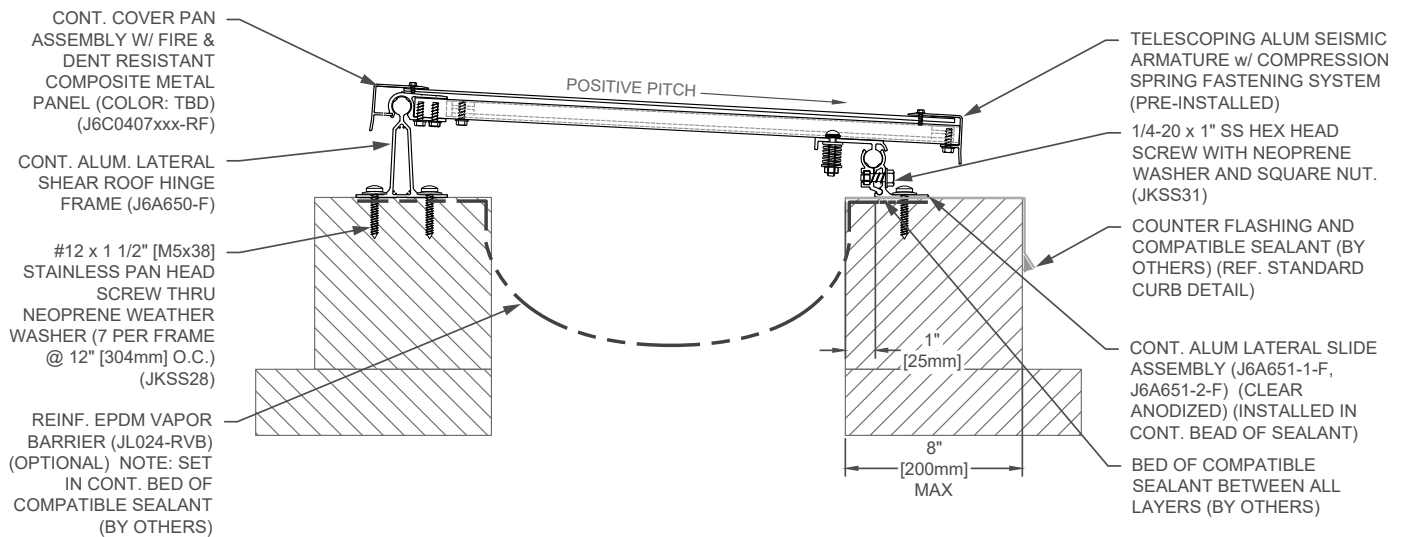

Curb Detail:

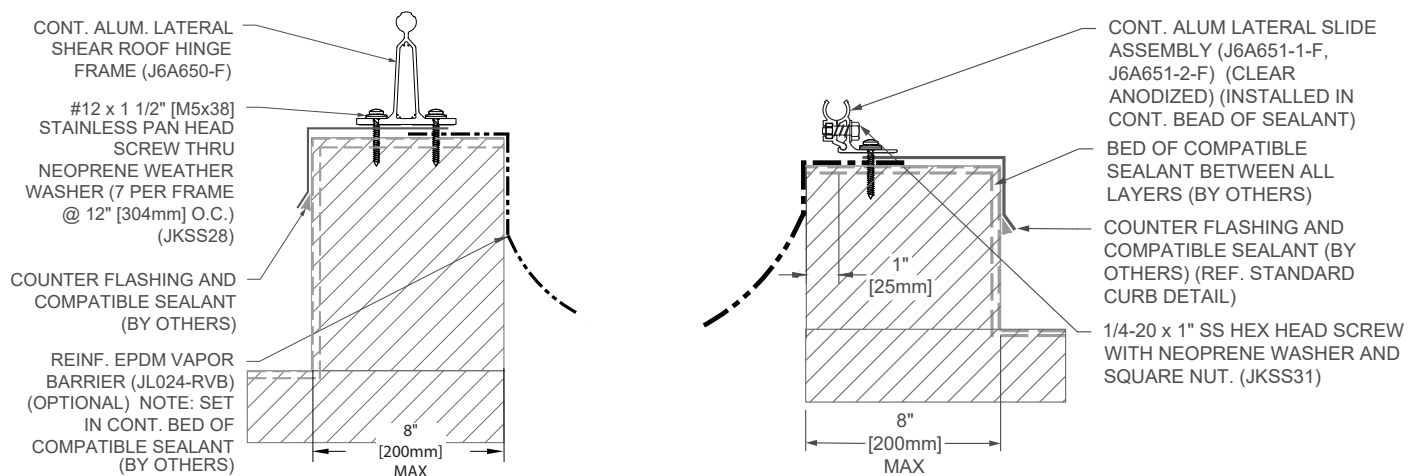

IPC.3539 / REV.1

JOINTMASTER® Expansion Joint Systems

inpro.com • 800.222.5556 • 262.679.9010

World Headquarters S80 W18766 Apollo Drive, Muskego, WI 53150 USA

Installation Hotline: 866.394.6776

inpro®

Installation Instructions

Joint System: 650C-A01

Components:

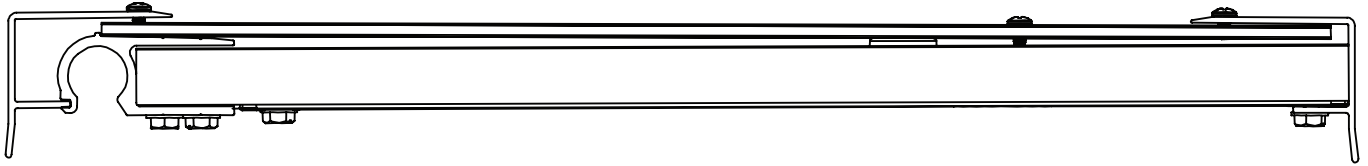

COVER PAN ASSEMBLY

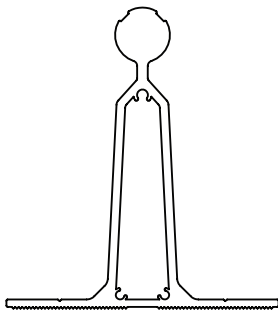

J6A650-F
ONE PIECE LATERAL
SHEAR ROOF HINGE

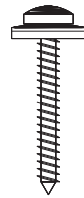

JKSS28
#12x1½" STAINLESS
PAN HEAD SCREW

TWO PIECE LATERAL SLIDE ASSEMBLY

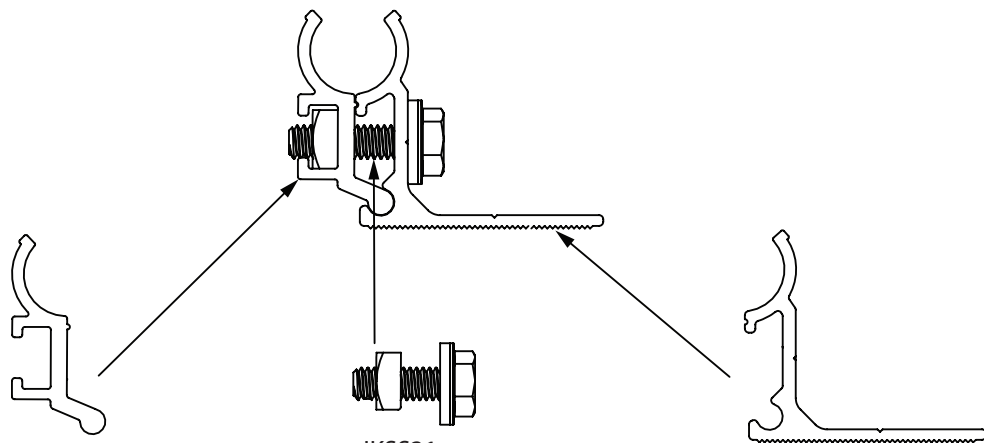

J6A651-2

JKSS31
1/4-20x1" BOLT W/
1/4-20 SQUARE NUT
QTY. 7

J6A651-1

JOINTMASTER® Expansion Joint Systems

inpro.com • 800.222.5556 • 262.679.9010

World Headquarters S80 W18766 Apollo Drive, Muskego, WI 53150 USA

Installation Hotline: 866.394.6776

inpro®

Installation Instructions

Joint System: 650C-A01

Assembly Overview:

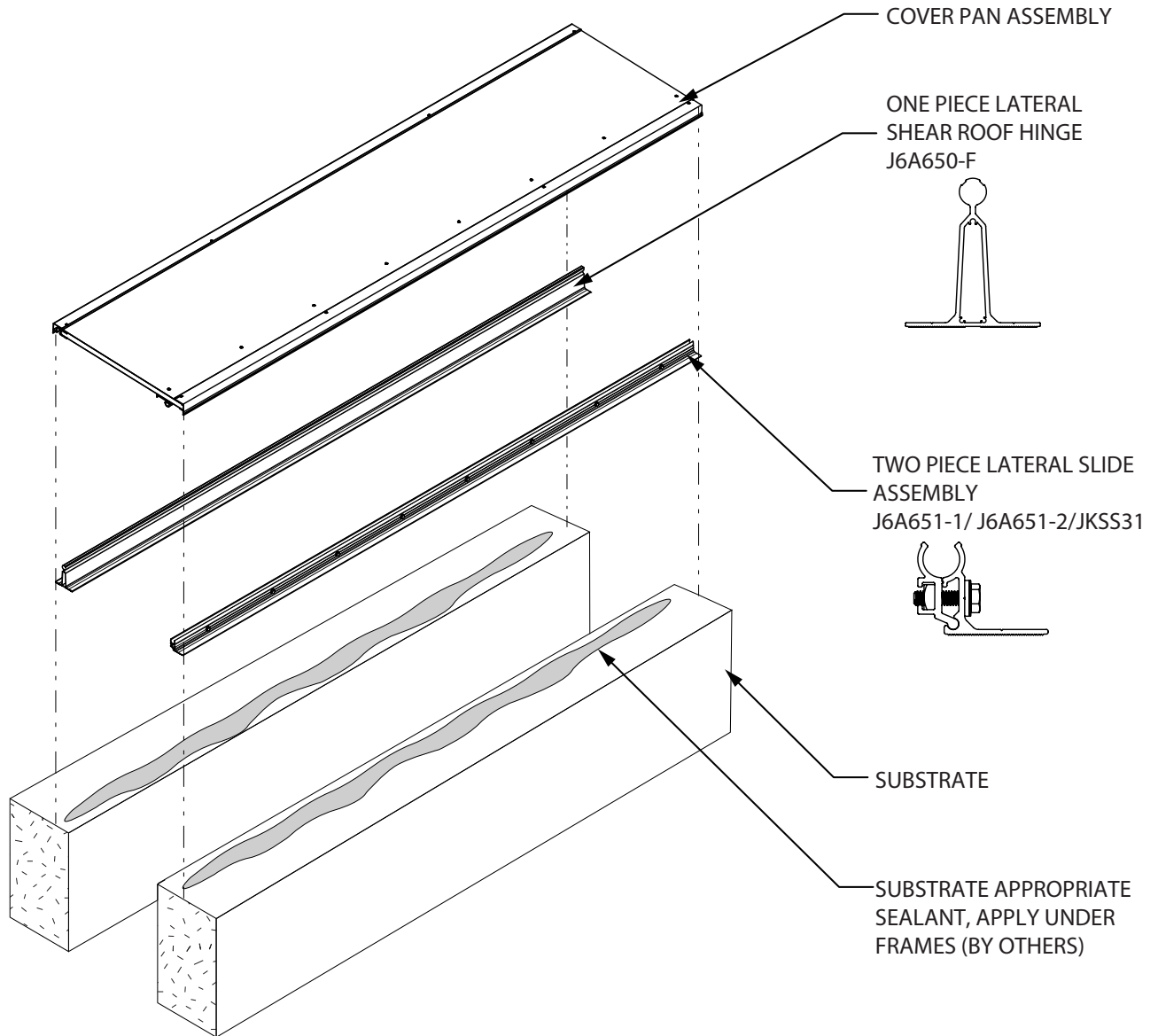

JOINTMASTER® Expansion Joint Systems

inpro.com • 800.222.5556 • 262.679.9010

World Headquarters S80 W18766 Apollo Drive, Muskego, WI 53150 USA

Installation Hotline: 866.394.6776

inpro®

Installation Instructions

Joint System: 650C-A01

Figure 1 Installing the Two Piece Lateral Slide Assembly

1. Slide J6A651-2 into J6A651-1. (See Fig.1)
2. Slide ¼-20 square nuts into extruded slot on J6A651-2. (See Fig.1.1)
3. Loosely thread the hex head screws with gasket washer into square nuts across the two piece lateral slide assembly. (See Fig.1.1)

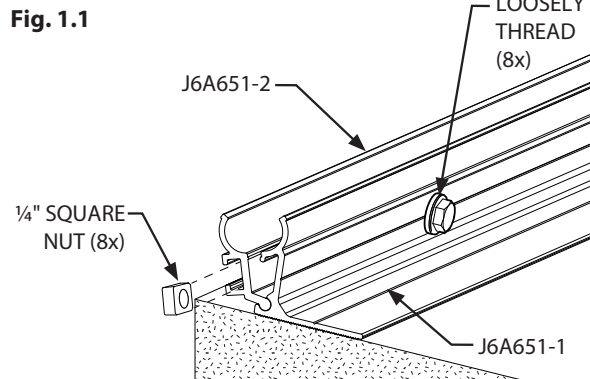
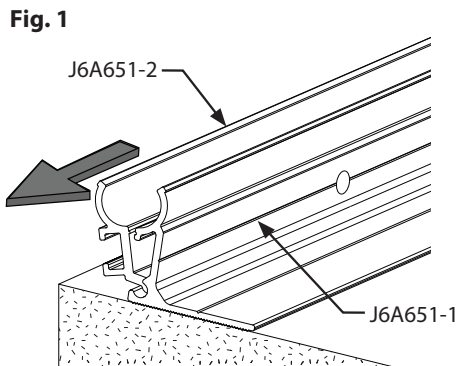
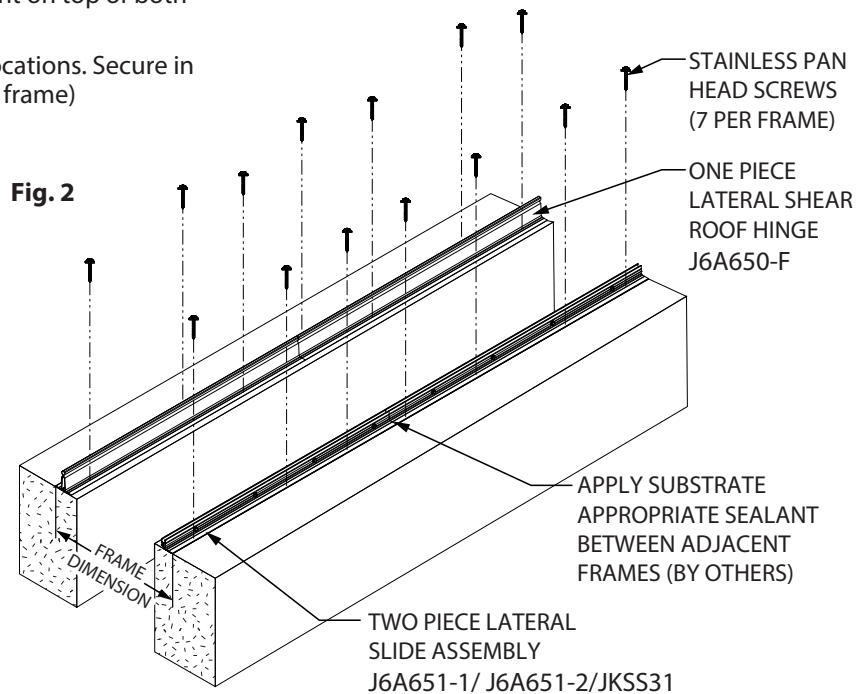

Figure 2 Installing the Frames

4. Place the frames firmly against the curb with frames positioned as shown(See Fig.2)
5. Reference project details and chart below to verify final frame positions. Ensure system is centered over Expansion Joint.
6. Mark the pre-drill hole locations on the curb and remove the frames.
7. Drill all marked holes on the curb using a 1/8" (3mm) drill bit to a 1 ½" (25mm) depth.
8. Lay continuous bed of substrate appropriate sealant on top of both curbs over vapor barrier membrane.
9. Return frames into position over the drilled hole locations. Secure in place with stainless steel pan head screws (7 per frame)

Joint Width		Frame to Frame Dimension	
US	MM	US	MM
6"	152	13 7/16"	341
8"	203	15 7/16"	391
10"	254	17 3/8"	442
12"	305	19 7/16"	493
14"	356	21 7/16"	544
16"	406	23 7/16"	595
18"	457	25 7/16"	645
20"	508	27 3/8"	696
22"	559	29 3/8"	747
24"	610	31 3/8"	798
26"	660	33 3/8"	849
28"	711	35 3/8"	899
30"	762	37 3/8"	950
32"	813	39 7/16"	1001



JOINTMASTER® Expansion Joint Systems

inpro.com • 800.222.5556 • 262.679.9010

World Headquarters S80 W18766 Apollo Drive, Muskego, WI 53150 USA

Installation Hotline: 866.394.6776

inpro®

Installation Instructions

Joint System: 650C-A01

Figure 3 Installing Cover Pan Assembly

10. Apply white lithium grease along entire length of cylindrical part of one piece lateral shear roof hinge (J6A650-1).

NOTE: At the end of a run, pre-assemble one piece frame into cover pan before installing.

11. Slide cover pan assembly onto the one piece lateral shear roof hinge until they are flush. (See Fig. 3)

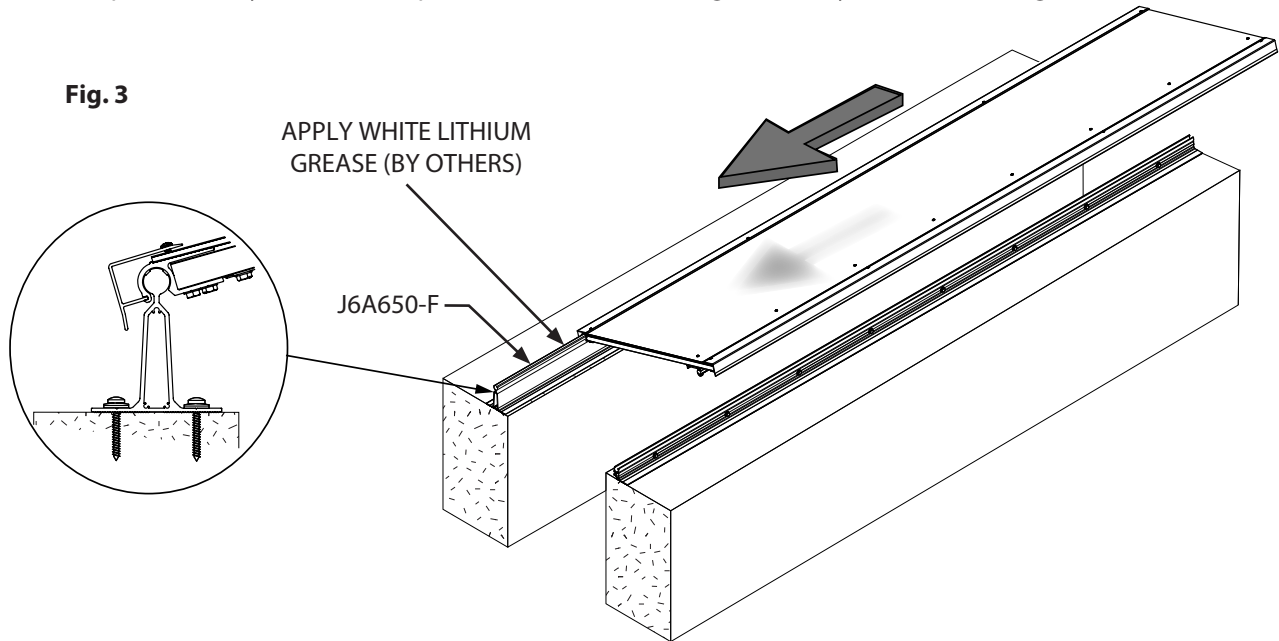

Figure 4 Installing Cover Pan Assembly

12. Rotate cover pan assembly, seating the lateral slide frame, into the two piece lateral slide assembly. (See Fig.4 & Fig.4.1)

Fig. 4

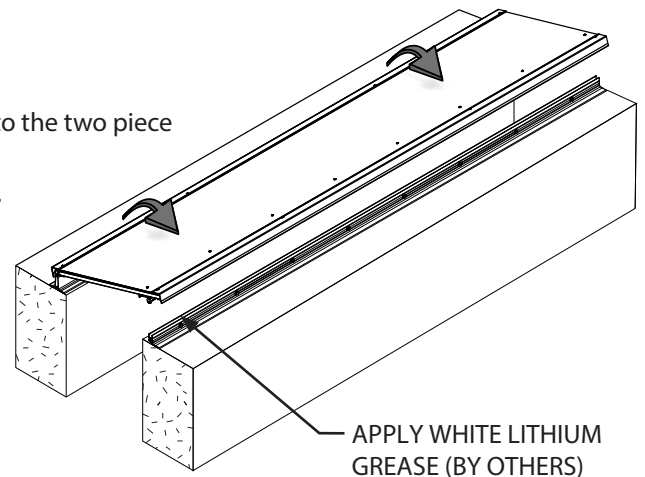
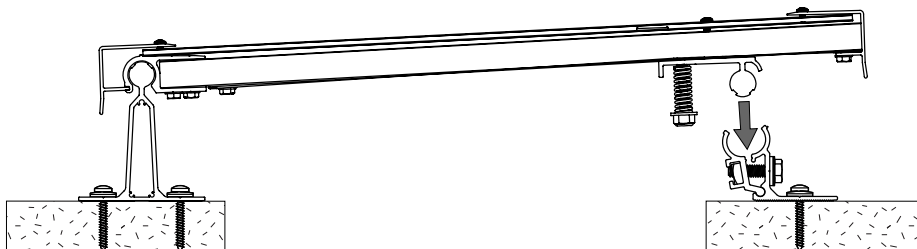

Fig.4.1



JOINTMASTER® Expansion Joint Systems

inpro.com • 800.222.5556 • 262.679.9010

World Headquarters S80 W18766 Apollo Drive, Muskego, WI 53150 USA

Installation Hotline: 866.394.6776

inpro®

Installation Instructions

Joint System: 650C-A01

Figure 5 Installing Cover Pan Assembly

13. Make sure the cover pan assembly rests in the two piece lateral slide assembly.(See Fig 5 and 5.1)

14. Using 7/16" socket, tighten JK31SS. (See Fig.5.2)

Fig. 5

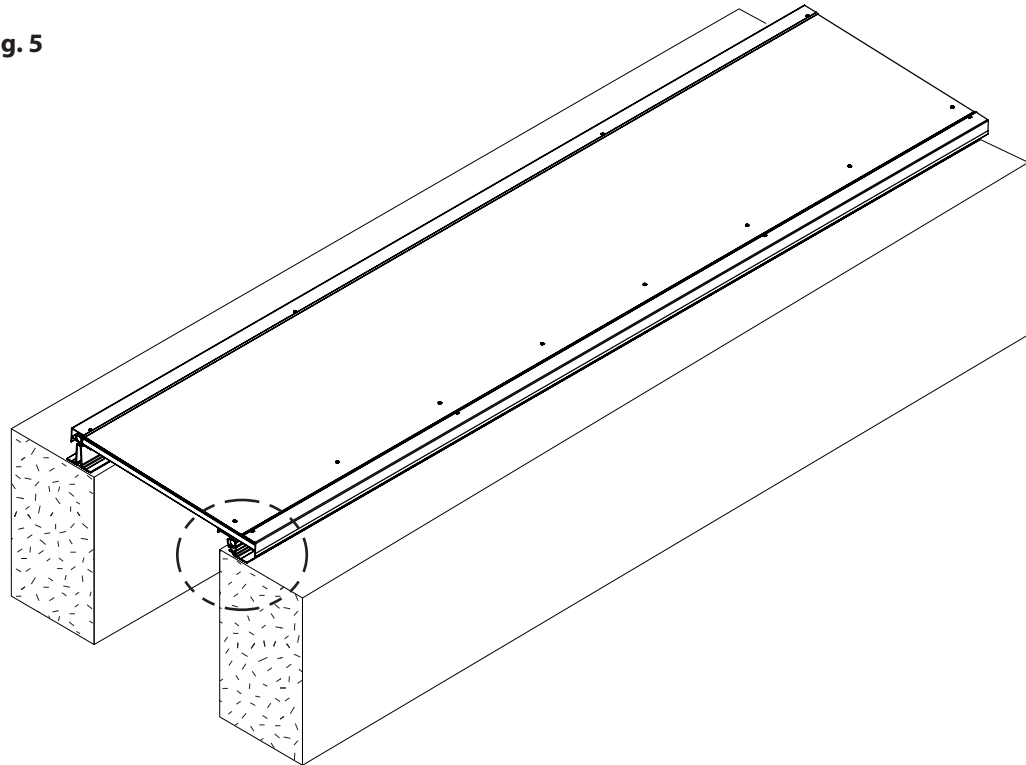

Fig. 5.1

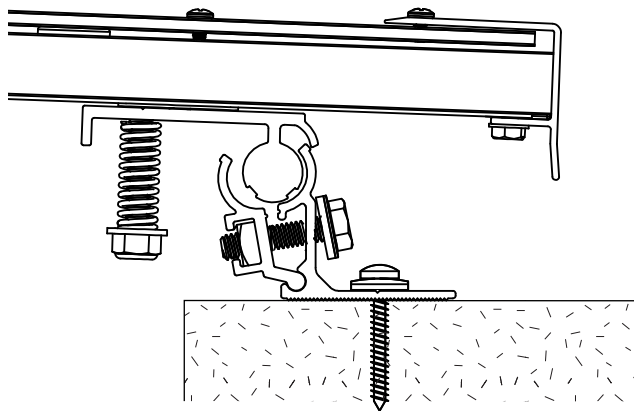
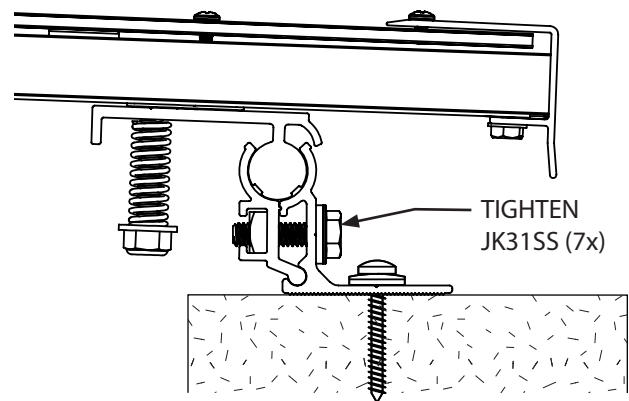

Fig. 5.2



JOINTMASTER® Expansion Joint Systems

inpro.com • 800.222.5556 • 262.679.9010

World Headquarters S80 W18766 Apollo Drive, Muskego, WI 53150 USA

Installation Hotline: 866.394.6776

inpro®

Installation Instructions

Joint System: 650C-A01

Figure 6 Installing Splice Plate

15. Clean area using isopropol alcohol or denatured alcohol.
16. Center splice plate where cover pan assemblies meet.
17. Apply system seam sealant to top of cover pan assemblies as shown. (See Fig.6)
18. Secure splice plate with two sheet metal screws 1" from edge of splice as shown below. (See Fig.6)

FIG.6

A01 to A01

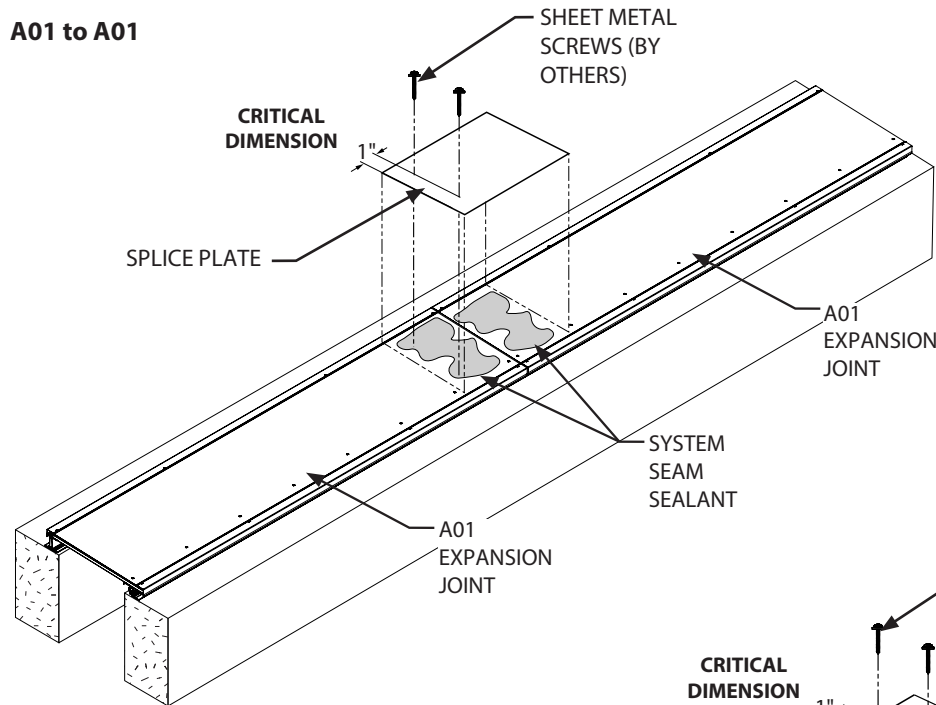
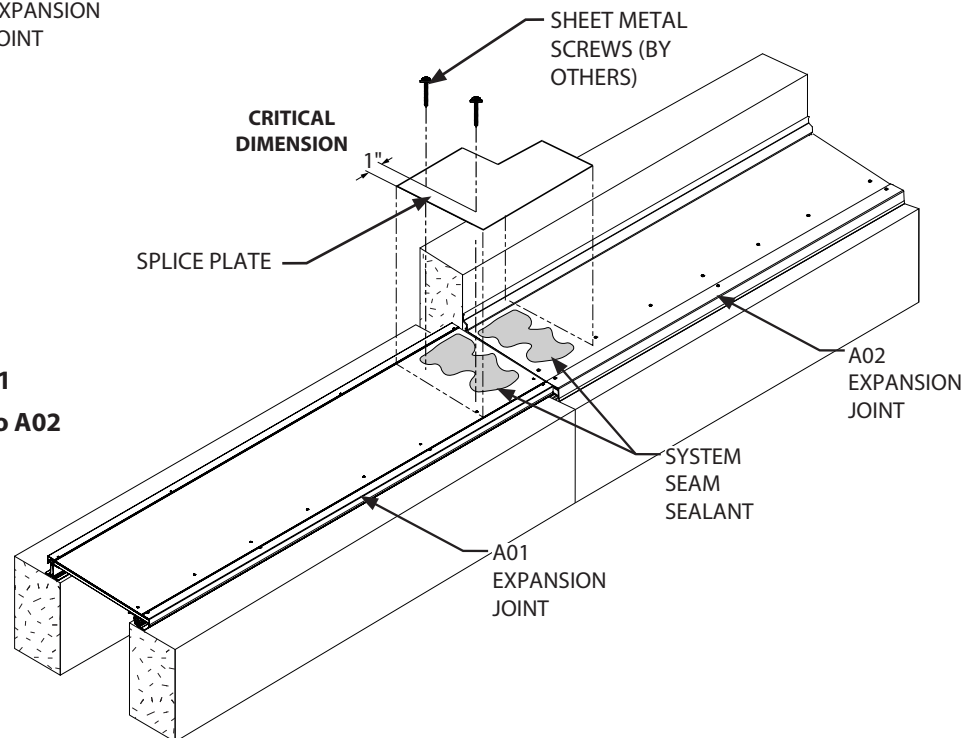

Fig.6.1

A01 to A02



JOINTMASTER® Expansion Joint Systems

inpro.com • 800.222.5556 • 262.679.9010

World Headquarters S80 W18766 Apollo Drive, Muskego, WI 53150 USA

Installation Hotline: 866.394.6776

inpro®